

## Catalogue worm gear sets and customised worm gear sets

Advanced production methods combined with years of experience in manufacturing gears and providing customers with sound advice have made Framo Morat's worm gear sets a byword for quality. In recent decades Framo Morat worm gear sets have won appreciable market shares both in Germany and abroad. Besides our catalogue worm gear sets (made to the Framo Morat standard), which we keep in stock in moderate quantities, we also manufacture customised worm gear sets in compliance with customer specifications. Our catalogue worm gear sets are generally available in a wide range of centre distances and transmission ratios directly from stock. Our factory can calculate and manufacture centre distances and transmission ratios deviating from the Framo Morat standard, although it will not always be possible to use available gear cutting tools. The worm gear sets are usually right-handed but can be produced left-handed on request. Depending on the transmission ratio, tooling will have to be procured first.

## Pressure Angle

Due to the manufacturing process, the teeth have a K flank shape. The pressure angle is generally 15° and therefore deviates from the DIN standard of 20°. A pressure angle of 15° allows more favourable radial force component conditions. This reduces the bending stress of the worm shaft and the pushing away of the associated worm gear, reducing the noise and increasing the service life. The efficiency differences due to the modification of the pressure angle are negligible.

## Metric conversion table

Our standard worm gear sets are primarily designed in metric scales. The catalog data can be converted into 'English measures' by using the following conversion table:

Metric units	Factor	English units
Torque (Nm)	x 8.85	in.lb.
Distance (mm)	x 0.03937	in.

## ISO-tolerances

The worm gear drawings show ISO-tolerances like  $\varnothing 32^{H7}$ . If you are not familiar with ISO-tolerances please call Framo Morat or the local distributor to get the precise dimensions.

## Construction materials

The worms are made of case hardened steel with ground bore and worm profile. The worm gears are made of a special alloy (copper-zinc alloy with additives of aluminum, silicon and manganese). Chemically this alloy belongs to the material group of CuZn40Al2 DIN 17660 (new according to EN: CuZn37Mn3Al2PbSi-S40) but is treated for better sliding characteristics. The chemical resistance is very high due to aluminum additives.

Mechanical characteristics:

- High corrosion resistance
- High mechanical strength:
 

Tensile strength $R_m$ :	560 N/mm <sup>2</sup>
Strain limit $R_{p0.2}$ :	290 N/mm <sup>2</sup>
Strain at failure $A_5$ :	15%
Hardness HB2,5/62,5:	140-170
Shearing strength:	470 N/mm <sup>2</sup>
Alternating stress:	170 N/mm <sup>2</sup> (20x10 <sup>6</sup> cycles)
- Good gliding characteristics
- High wear resistance

## Plastic worm gears

Plastic worm gears are suitable for low sliding speeds (< 1.5 m/s) and medium tooth pressure due to their bad thermal conductivity. Worms have to be hardened and ground.

Plastic worm gears are suitable for 50% torque of bronze worm gears.

Mechanical characteristics:	POM	PA 66
Tensile strength $R_m$ with 23°C:	70 N/mm <sup>2</sup>	50 N/mm <sup>2</sup>
Tensile strength $R_m$ with 70°C:	48 N/mm <sup>2</sup>	35 N/mm <sup>2</sup>
Temperature range:	-50 .... +100°C	-40 .... +100°C

## Worm gear sets

The thermal expansion coefficient is appr. 4 times higher than with bronze. Therefore the backlash shouldn't be too small. At the limit temperature of 100°C the mechanical values drop to 40% of the nominal values. The case temperature shouldn't exceed 50°C, which means the temperature of the gears must not exceed 70°C.

Market offers a variety of different bronze for worm gears. Some of them are described here. "Soft" bronze is good for higher speed, "hard" bronze is good for lower speed. "Soft" bronze worm gears can be paired with unhardened steel worms but that means reductions in torque and life time. "Hard" bronze worm gears can only be paired with hardened steel worms.

### **Cu Sn 12 DIN 1705**

Comparatively soft material with good wear resistance, suitable for high sliding speeds.

	<i>G-CuSn12</i>	<i>GZ-CuSn12</i>	<i>GC-CuSn12</i>
Tensile strength $R_m$ :	260 N/mm <sup>2</sup>	280 N/mm <sup>2</sup>	280 N/mm <sup>2</sup>
Strain limit $R_{p0,2}$ :	140 N/mm <sup>2</sup>	150 N/mm <sup>2</sup>	140 N/mm <sup>2</sup>
Strain at failure $A_5$ :	12 %	5 %	8 %
Hardness HB10:	80	95	90

### **Cu Sn 12 Ni DIN 1705**

Comparatively soft material with very good wear resistance, suitable for very high sliding speeds.

	<i>G-CuSn12Ni</i>	<i>GZ-CuSn12Ni</i>	<i>GC-CuSn12Ni</i>
Tensile strength $R_m$ :	280 N/mm <sup>2</sup>	300 N/mm <sup>2</sup>	300 N/mm <sup>2</sup>
Strain limit $R_{p0,2}$ :	160 N/mm <sup>2</sup>	180 N/mm <sup>2</sup>	170 N/mm <sup>2</sup>
Strain at failure $A_5$ :	14 %	8 %	10 %
Hardness HB10:	90	100	90

G = dead mold casting  
 GZ = centrifugal casting  
 GC = continuous casting

### **CuAl10Fe3 Mn2 DIN 17665 / 17672**

Comparatively hard material for high torque and low speed.

	<i>CuAl10Fe3 Mn2</i>	<i>CuAl10Ni5F4</i>
Tensile strength $R_m$ :	590 N/mm <sup>2</sup>	700 N/mm <sup>2</sup>
Strain limit $R_{p0,2}$ :	250 N/mm <sup>2</sup>	300 N/mm <sup>2</sup>
Strain at failure $A_5$ :	12 %	13 %
Hardness HB 2,5 / 62,5:	150	160

### **Torque factor**

The catalog torque ratings are based on 2,800 rpm worm speed. The following table shows the torque factors for different worm speeds:

$n_1$	2800 rpm	1400 rpm	950 rpm	700 rpm	500 rpm	250 rpm	125 rpm
Factor $n_1$	1	1,12	1,2	1,26	1,33	1,49	1,67

### **Lifetime factor**

The catalog torque ratings are based on 3000 hours expected lifetime. The following table shows the torque ratings for different lifetimes:

life time	appr. 3000 h	appr. 1500 h	appr. 6000 h
factor $L_n$	1	1,4	0,71

Subject to technical changes

## 1. Calculation example (*without* consideration of the operating conditions)

worm gear set A40 U35, lubrication with mineral oil,  
worm speed 700 min<sup>-1</sup>, life time 1500 h

Question: What's the expected maximum torque?

$$\begin{aligned}
 \text{Output torque:} &= T_2 \text{ (Mineral oil)} \times n_1 \text{ (Factor)} \times L_h \text{ (Factor)} \\
 &= 37,2 \text{ Nm} \times 1,26 \times 1,4 && T_2 \text{ see table on page 14} \\
 &= 65,6 \text{ Nm}
 \end{aligned}$$

**Attention!** The torque is limited by the tooth strength of the gear. The tooth strength is reached at approx. 300% of the catalog specification for synthetic oil (T<sub>2</sub> SO).  
EXAMPLE: Breaking point for A40 U35 = 46,5 Nm x 3 = 139,5 Nm.

### Application factors

Due to the wide range of applications the following factors are recommendations which enable the customer to choose the correct configuration. The case temperature shouldn't exceed 80°C.

Shocks	none	moderate	heavy
shock factor f <sub>1</sub>	1	1,2	1,5
No. of starts	10/h	60/h	360/h
start factor f <sub>2</sub>	1	1,1	1,2
duty cycle	<40 %	<70 %	<100 %
duty cycle factor f <sub>3</sub>	1	1,15	1,3

## 2. Calculation example (*with* consideration of the operating conditions)

worm gear set A40 U35; T<sub>2</sub> = 65,6 Nm (see above), but with the following operating conditions:  
- heavy shocks  
- 360 starts / h  
- 100 % duty cycle

$$\begin{aligned}
 \text{Output torque} &= \frac{T_2}{f_1 \times f_2 \times f_3} \\
 &= \frac{65,6 \text{ Nm}}{1,5 \times 1,2 \times 1,3} \\
 &= 28 \text{ Nm}
 \end{aligned}$$

The relationship between life time, speed and torque can be calculated by these simplified formulas

Calculation of the life time (L<sub>h neu</sub>) with given torque (T<sub>2 neu</sub>)

$$L_{h \text{ neu}} = \left( \frac{T_{2 \text{ Nenn.}} \times \text{Factor } n_1}{T_{2 \text{ neu}}} \right)^2 \cdot L_{h \text{ Nenn.}}$$

T<sub>2 Nenn.</sub> = Output torque (catalog specification)

L<sub>h Nenn.</sub> = Life time (catalog specification ca. 3000 h)

## Worm gear sets

Calculation of the torque ( $T_{2\text{neu}}$ ) with given life time ( $L_{\text{hneu}}$ )

$$T_{2\text{neu}} = \frac{T_{2\text{Nenn}} \times \text{Factor } n_1}{\sqrt{\frac{L_{\text{hneu}}}{L_{\text{hNenn}}}}}$$

### Self locking

Self-locking is affected by lead angle, surface quality, running speed, lubrication and temperature. A distinction must be made between dynamic (from motion) and static (standstill) self-locking.

**Dynamic self locking:** lead angle up to  $3^\circ$  with grease lubrication; lead angle up to  $2,5^\circ$  with synthetic oil lubrication.

**Static self locking:** lead angle from  $3^\circ$  up to  $5^\circ$  with grease lubrication; lead angle from  $2,5^\circ$  up to  $4,5^\circ$  with synthetic oil lubrication.

Lead angles above  $4,5^\circ$  or  $5^\circ$  are not self locking.

Shocks or vibrations can neutralize self-locking.

A number of factors associated with lubrication, running speed and loading can favour slip characteristics to such an extent that self-locking is counteracted.

Therefore it is impossible for us to accept warranty obligations in respect to self-locking.

### Mounting of the worm gear

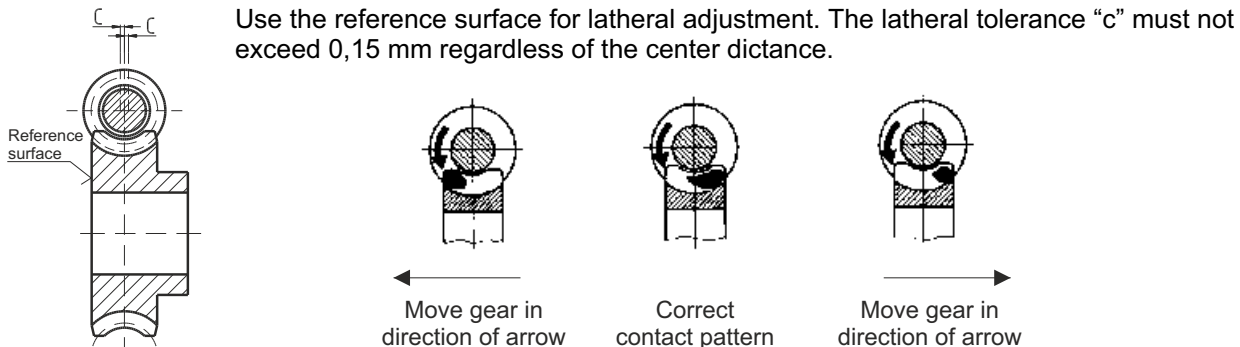

The contact pattern shows installation errors. The contact pattern should tend to the outgoing side. In case of reversing operation the contact pattern should tend to the center of the worm gear.

### Efficiency

Generally efficiency depends on the following conditions:

- lead angle of the worm,
- running speed,
- lubrication,
- surface quality,
- mounting conditions.

The efficiency increases with growing center distance. The use of plain bearings with high coefficients of friction may affect the overall efficiency. The stated efficiency values apply for optimum mounting conditions.

### Starting efficiency

The lubricating film between the flanks is not formed until the gear is running. That is the reason for a lower starting efficiency (approx. 30% below running efficiency).

## Efficiency with driving worm gear

The efficiency with driving worm gear is smaller than with driving worm. The following formula can be used:

$$\eta' = 2 - \frac{1}{\eta}$$

with:  $\eta'$  => efficiency with driving worm gear  
 $\eta$  => efficiency with driving worm (specified in catalog)

if  $\eta'$  is negative, self locking is likely.

## Customer-Specific Worm Gear Sets

Customised worm gear sets can be manufactured in compliance with customer specifications in various versions and materials.

Framo Morat supplies customised worm gear sets in a centre distance range from 17 to 125 mm, with a max. worm gear diameter of 200 mm. If necessary, Framo Morat calculates the tothing data, defines the materials and surface treatment, and provides advice for lubrication and torque loads.

We use to that purpose a calculation programme based on the DIN standard. Framo Morat's vast experience gained all along 60 years of worm gear sets production has shown that, especially in the case of short delivery times and small quantities, our customer mainly opt for existing gear cutting tools. The production method must then be examined on a case-by-case basis.

## Crossed helical gears

Crossed helical gears are nothing but a spur gear, which helix angle meets the lead angle of the worm. The gliding surface is only a line. The result is reduced torque or reduced life time compared with conventional worm gear sets.



## A17 (17 mm center distance)

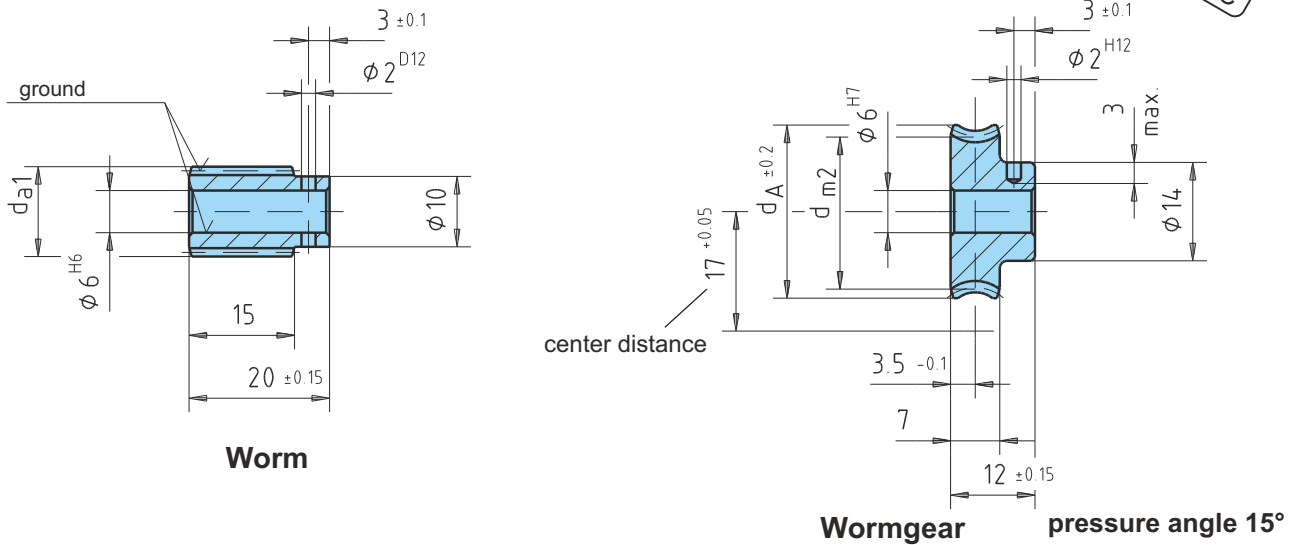

$i$  = gear ratio  
 $\alpha_m$  = lead angle  
 $m$  = module  
 $z_1$  = number of threads  
 $d_{m1}$  = pitch diameter (worm)

$d_{a1}$  = tip diameter (worm)  
 $z_2$  = No. of teeth  
 $d_{m2}$  = pitch diameter (worm gear)  
 $d_A$  = max. diameter (worm gear)  
 $T_2$  = output torque

MG = mineral grease  
 MO = mineral oil / synthetic grease  
 SO = synthetic oil

Catalog	i	$\alpha_m$	m	worm			wormgear			T <sub>2</sub> [Nm] No.			
				z <sub>1</sub>	d <sub>m1</sub>	d <sub>a1</sub>	z <sub>2</sub>	d <sub>m2</sub>	d <sub>A</sub>	Bronze			Phenolic
										MG	MO	SO	
A17U2*	2.25	48°15'	0.9	8	10.15	11.95	18	23.85	25.63	1.1	1.3	1.6	0.4
A17U4	4.5	21°50'	0.75	6	12.1	13.6	27	21.9	24.6	1.7	2.0	2.6	0.7
A17U5	5	21°37'	0.7	6	11.4	12.8	30	22.6	24.6	1.8	2.2	2.7	0.7
A17U7	7	14°4'	1	3	12.34	14.34	21	21.66	24.6	1.6	1.9	2.4	0.6
A17U9	9	9°40'	0.75	3	13.4	14.9	27	20.6	22.7	1.5	1.8	2.2	0.6
A17U10	10	11°48'	0.75	3	11.0	12.5	30	23.0	24.6	1.9	2.3	2.8	0.8
A17U15	15	7°38'	0.75	2	11.3	12.8	30	22.7	24.6	1.9	2.3	2.8	0.8
A17U25	25	4°32'	0.9	1	11.4	13.2	25	22.6	24.6	1.8	2.2	2.7	0.7
A17U30	30	3°45'	0.75	1	11.45	12.95	30	22.55	24.6	1.9	2.3	2.8	0.8
A17U40	40	2°3'	0.5	1	13.98	14.98	40	20.02	21.6	1.4	1.7	2.1	0.6
A17U50**	50	3°12'	0.5	1	8.95	9.95	50	25.05	27.2	1.0	1.2	1.5	0.4
A17U60	60	2°18'	0.4	1	9.95	10.75	60	24.05	26.0	1.6	1.9	2.4	0.6
A17U75	75	1°28'	0.3	1	11.74	12.34	75	22.26	24.0	1.5	1.8	2.2	0.5
A17U80	80	1°43'	0.3	1	10.0	10.84	80	24.0	25.1	1.5	1.8	2.2	0.5

\* Worm gear set A17U2 only available with polished worm profile and crossed helical gear.

\*\* The hub diameter of the A17U50 worm is 9 mm.

All worms and worm gears stocked right hand only.

Worm made of case hardened and ground steel (HV 620 - 700).

Worm gear made of CuZn37Mn3Al2PbSi-S40 or at request of plastic or Hgw 2083. Phenolic worm gears do not have the pre-drilled start for a pin. The outside diameter of the phenolic gear hub is 18 mm.



## A22 (22.62 mm center distance)

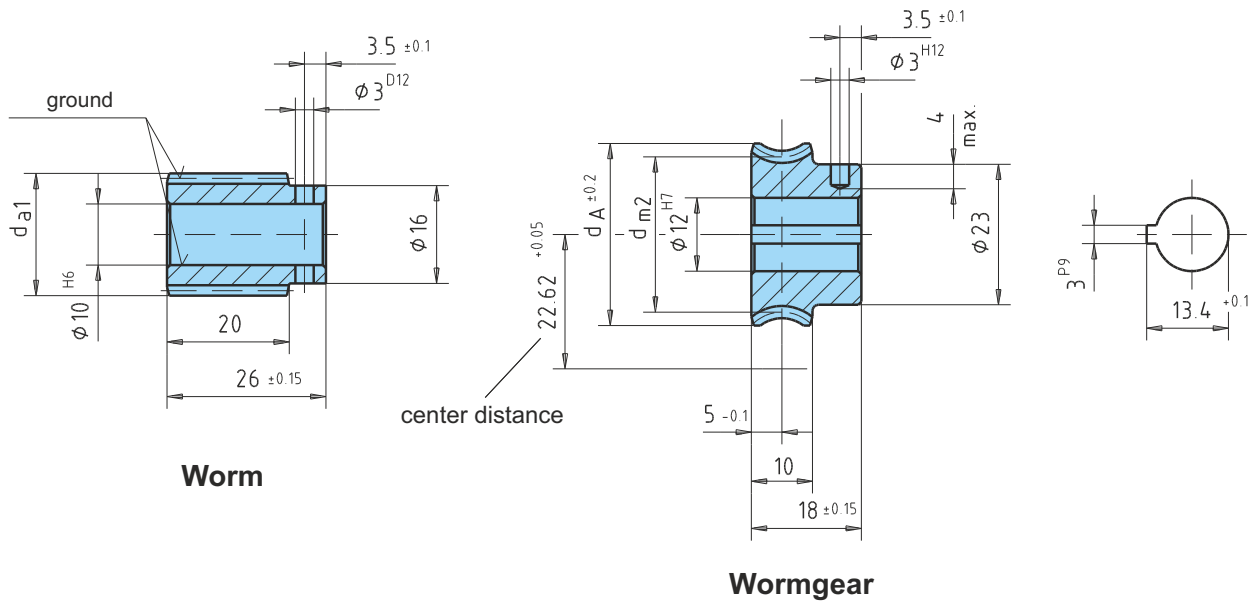

pressure angle 15°

$i$  = gear ratio  
 $\alpha_m$  = lead angle  
 $m$  = module  
 $z_1$  = number of threads  
 $d_{m1}$  = pitch diameter (worm)

$d_{a1}$  = tip diameter (worm)  
 $z_2$  = No. of teeth  
 $d_{m2}$  = pitch diameter (worm gear)  
 $d_A$  = max. diameter (worm gear)  
 $T_2$  = output torque

MG = mineral grease  
 MO = mineral oil / synthetic grease  
 SO = synthetic oil

Catalog				worm			wormgear			$T_2$ [Nm] No.			
	$i$	$\alpha_m$	$m$	$z_1$	$d_{m1}$	$d_{a1}$	$z_2$	$d_{m2}$	$d_A$	Bronze	Phe- nolic		
										MG	MO	SO	
<b>A22U3</b>	3:1	17°36'	1.0	7	23.15	25.15	21	22.09	24.8	2.2	2.6	3.3	0.9
<b>A22U4</b>	4:1	19°32'	1.25	5	18.7	21.2	20	26.54	29.8	3.6	4.3	5.4	1.4
<b>A22U7</b>	7:1	11°46'	1.25	3	18.4	20.9	21	26.84	29.8	3.6	4.3	5.4	1.4
<b>A22U11</b>	10.5:1	7°41'	1.25	2	18.7	21.2	21	26.54	29.8	3.4	4.1	5.1	1.4
<b>A22U21</b>	21:1	3°48'	1.25	1	18.9	21.4	21	26.34	29.8	3.4	4.1	5.1	1.4
<b>A22U30</b>	30:1	2°50'	0.9	1	18.2	20	30	27.04	29.8	3.6	4.3	5.4	1.4
<b>A22U40</b>	40:1	2°20'	0.7	1	17.2	18.6	40	28.04	29.8	3.9	4.7	5.8	1.6

All worms and worm gears stocked right hand only.

Worm made of case hardened and ground steel (HV 620 - 700).

Worm gear made of CuZn37Mn3Al2PbSi-S40 or at request of plastic or Hgw 2083.

Subject to technical changes

METRIC

## A25 (25 mm center distance)

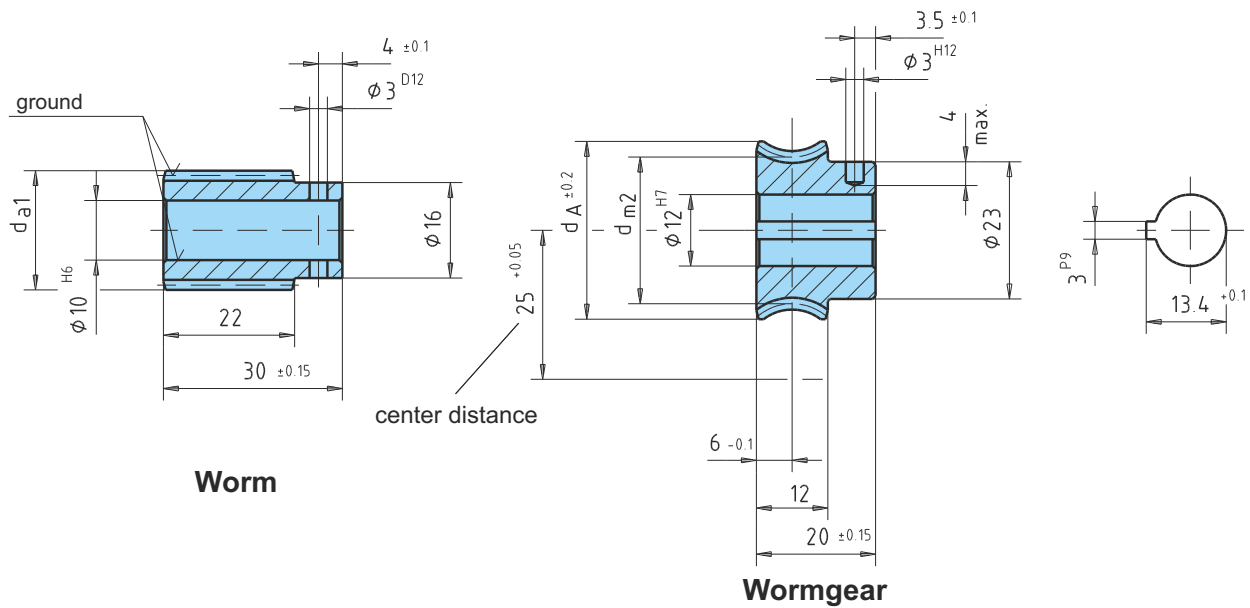

pressure angle 15°

$i$  = gear ratio  
 $\alpha_m$  = lead angle  
 $m$  = module  
 $z_1$  = number of threads  
 $d_{m1}$  = pitch diameter (worm)

$d_{a1}$  = tip diameter (worm)  
 $z_2$  = No. of teeth  
 $d_{m2}$  = pitch diameter (worm gear)  
 $d_A$  = max. diameter (worm gear)  
 $T_2$  = output torque

MG = mineral grease  
 MO = mineral oil / synthetic grease  
 SO = synthetic oil

Catalog	i	$\alpha_m$	m	worm			wormgear			$T_2$ [Nm] No.			
				$z_1$	$d_{m1}$	$d_{a1}$	$z_2$	$d_{m2}$	$d_A$	Bronze			Phe- nolic
										MG	MO	SO	
A25U4	4:1	20°29'	1.4	5	20	22.8	20	30.0	33.5	5.1	6.1	7.6	2.0
A25U5	5:1	19°15'	1.5	4	18.2	21.2	20	31.8	34.8	6.5	7.8	9.7	2.6
A25U6	6.5:1	13°52'	1.15	4	19.2	21.5	26	30.8	34.8	6	7.2	9	2.4
A25U10	10:1	8°48'	1.5	2	19.6	22.6	20	30.4	34.8	5.9	7.1	8.8	2.4
A25U15	15:1	6°29'	1.0	2	17.7	19.7	30	32.3	34.8	5.7	6.8	8.5	2.3
A25U20	20:1	4°19'	1.5	1	19.9	22.9	20	30.1	34.8	5.8	7.0	8.7	2.3
A25U25	25:1	2°18'	1.0	1	24.96	26.96	25	25.04	27.8	4.1	4.9	6.1	1.6
A25U30	30:1	2°53'	1.0	1	19.9	21.9	30	30.1	33.5	5.9	7.1	8.8	2.4
A25U40	40:1	2°33'	0.8	1	17.96	19.56	40	32.04	34.8	6.2	7.4	9.3	2.5
A25U50	50:1	1°43'	0.6	1	19.96	21.16	50	30.04	33.5	5.1	6.1	7.6	2.0

All worms and worm gears stocked right hand only.  
 Worm made of case hardened and ground steel (HV 620 - 700).  
 Worm gear made of CuZn37Mn3Al2PbSi-S40 or at request of plastic or Hgw 2083.



## A31 (31 mm center distance)

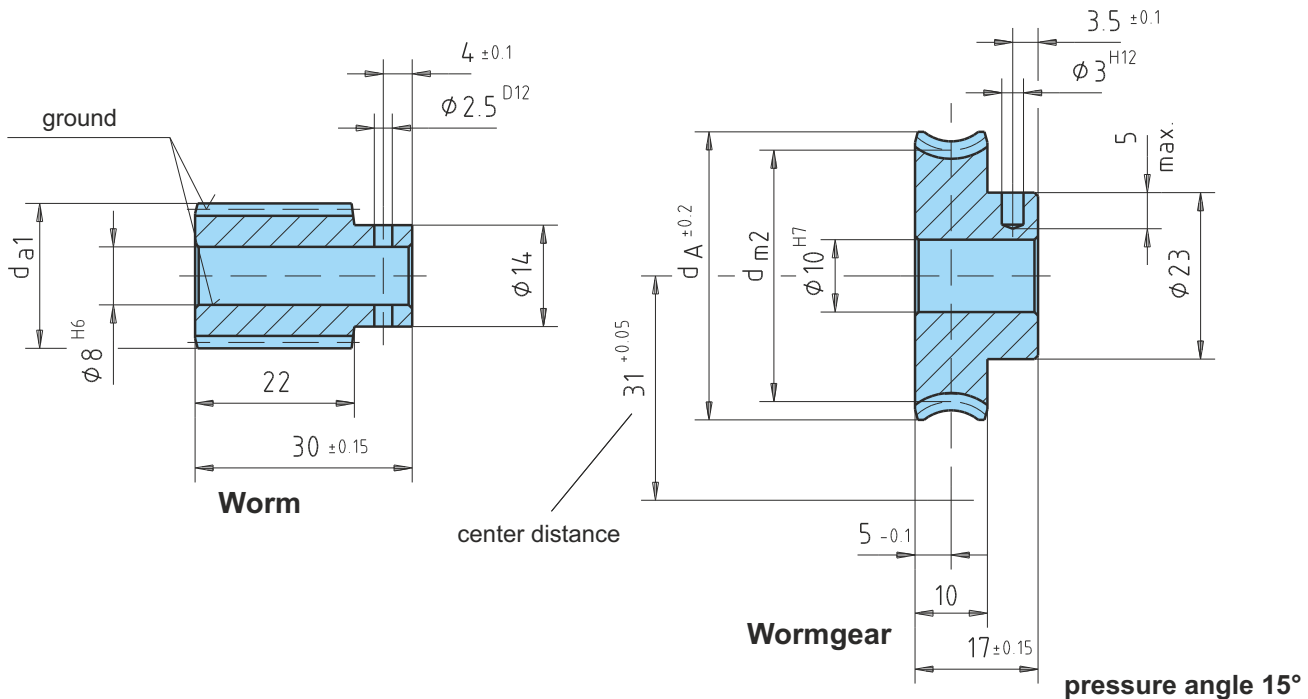

$i$  = gear ratio  
 $m$  = lead angle  
 $m$  = module  
 $z_1$  = number of threads  
 $d_{m1}$  = pitch diameter (worm)

$d_{a1}$  = tip diameter (worm)  
 $z_2$  = No. of teeth  
 $d_{m2}$  = pitch diameter (worm gear)  
 $d_A$  = max. diameter (worm gear)  
 $T_2$  = output torque

MG = mineral grease  
 MO = mineral oil / synthetic grease  
 SO = synthetic oil

Catalog	$i$	$m$	$m$	worm			wormgear			$T_2$ [Nm] No.			
				$z_1$	$d_{m1}$	$d_{a1}$	$z_2$	$d_{m2}$	$d_A$	Bronze			Phe- nolic
										MG	MO	SO	
A31U2*	2.5:1	45°15'	1.25	10	17.6	20.1	25	44.4	46.9	4.4	5.3	6.6	1.7
A31U3	3:1	35°10'	1.15	10	19.97	22.27	30	42.03	44.5	4.5	5.4	6.7	1.8
A31U4	4.28:1	25°24'	1.25	7	20.4	22.9	30	41.6	45	9	10.8	13.5	3.6
A31U5	5:1	23°46'	1.3	6	19.35	21.95	30	42.65	46.5	9.5	11.4	14.2	3.8
A31U6	6:1	18°13'	1.3	5	20.8	23.4	30	41.2	45	7.6	9.1	11.4	3.0
A31U7	7:1	20°32'	1.5	4	17.1	20.1	28	44.9	48.8	9.7	11.6	14.5	3.9
A31U8	8.33:1	19°49'	1.75	3	15.5	19	25	46.5	51	10	12	15	4.0
A31U10	10:1	12°50'	1.4	3	18.9	21.7	30	43.1	47	9.5	11.4	14.2	3.8
A31U12	12:1	13°55'	1.25	3	15.6	18.1	36	46.4	50	12.1	14.5	18.1	4.8
A31U15	15:1	10°40'	1.5	2	16.2	19.2	30	45.8	50	10.7	12.8	16	4.3
A31U18/1.25	18:1	8°44'	1.25	2	16.46	18.96	36	45.54	48.8	10.3	12.4	15.4	4.1
A31U20/0.75	20:1	7°49'	0.75	3	16.54	18.04	60	45.46	48	8.3	10	12.4	3.3
A31U20/1.15	20:1	8°33'	1.15	2	15.47	17.77	40	46.53	50	10.3	12.4	15.4	4.1
A31U22	22:1	6°29'	1	2	17.7	19.7	44	44.3	48	9.6	11.5	14.4	3.8
A31U23	23:1	7°29'	2	1	15.35	19.35	23	46.65	52	10.5	12.6	15.7	4.2
A31U24	24:1	5°4'	1.75	1	19.8	23.3	24	42.2	47	9.2	11	13.8	3.7

\* Worm gear set only available with polished worm profile and crossed helical gear.

All worms and worm gears stocked right hand only, worm made of case hardened and ground steel (HV 620 - 700). Worm gear made of CuZn37Mn3Al2PbSi-S40 or at request of plastic or Hgw 2083.

Subject to technical changes

METRIC

# A31 (31 mm center distance)

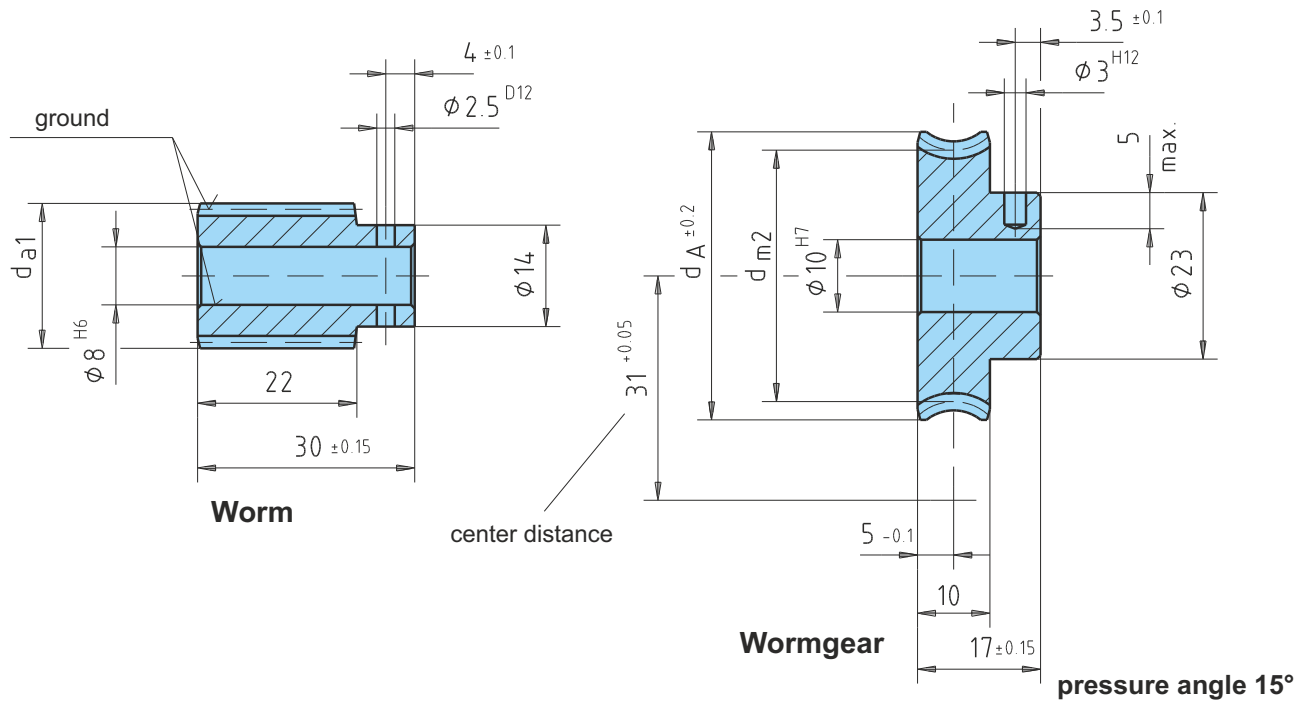

$i$  = gear ratio  
 $\alpha_m$  = lead angle  
 $m$  = module  
 $z_1$  = number of threads  
 $d_{m1}$  = pitch diameter (worm)

$d_{a1}$  = tip diameter (worm)  
 $z_2$  = No. of teeth  
 $d_{m2}$  = pitch diameter (worm gear)  
 $d_A$  = max. diameter (worm gear)  
 $T_2$  = output torque

MG = mineral grease  
 MO = mineral oil / synthetic grease  
 SO = synthetic oil

Catalog	i	$\alpha_m$	m	worm			wormgear			$T_2$ [Nm] No.			
				$z_1$	$d_{m1}$	$d_{a1}$	$z_2$	$d_{m2}$	$d_A$	Bronze			Phe- nolic
										MG	MO	SO	
A31U25	25:1	5°35'	1.75	1	18	21.5	25	44	48.5	9.6	11.5	14.4	3.8
A31U28	28:1	4°20'	1.5	1	19.85	22.85	28	42.15	46.5	9.1	10.9	13.6	3.6
A31U30	30:1	5°7'	1.5	1	16.8	19.8	30	45.2	48.8	10.3	12.4	15.4	4.1
A31U32	32:1	4°45'	1.4	1	16.9	19.7	32	45.1	48.8	10.2	12.2	15.3	4.1
A31U38	38:1	5°1'	1.25	1	14.3	16.8	38	47.7	51.2	11.4	13.7	17.1	4.6
A31U45	45:1	3°23'	1	1	16.93	18.93	45	45.07	48	9.5	11.4	14.2	3.8
A31U50	50:1	3°3'	0.9	1	16.9	18.7	50	45.1	48	9	10.8	13.5	3.6
A31U55	55:1	4°12'	0.9	1	12.3	14.1	55	49.7	52	10.4	12.5	15.6	4.2
A31U60	60:1	2°33'	0.75	1	16.9	18.4	60	45.1	48	8.2	9.8	12.3	3.3
A31U70	70:1	3°7'	0.7	1	12.9	14.3	70	49.1	52	9	10.8	13.5	3.6
A31U75	75:1	2°2'	0.6	1	16.9	18.1	75	45.1	47	7.3	8.8	10.9	2.9
A31U90	90:1	1°41'	0.5	1	17	18	90	45	48	6.4	7.7	9.6	2.6
A31U100	100:1	2°24'	0.5	1	11.96	12.96	100	50.04	52.7	7.4	8.9	11.1	3.0

All worms and worm gears stocked right hand only, worm made of case hardened and ground steel (HV 620 - 700). Worm gear made of CuZn37Mn3Al2PbSi-S40 or at request of plastic or Hgw 2083.



## A33 (33 mm center distance)

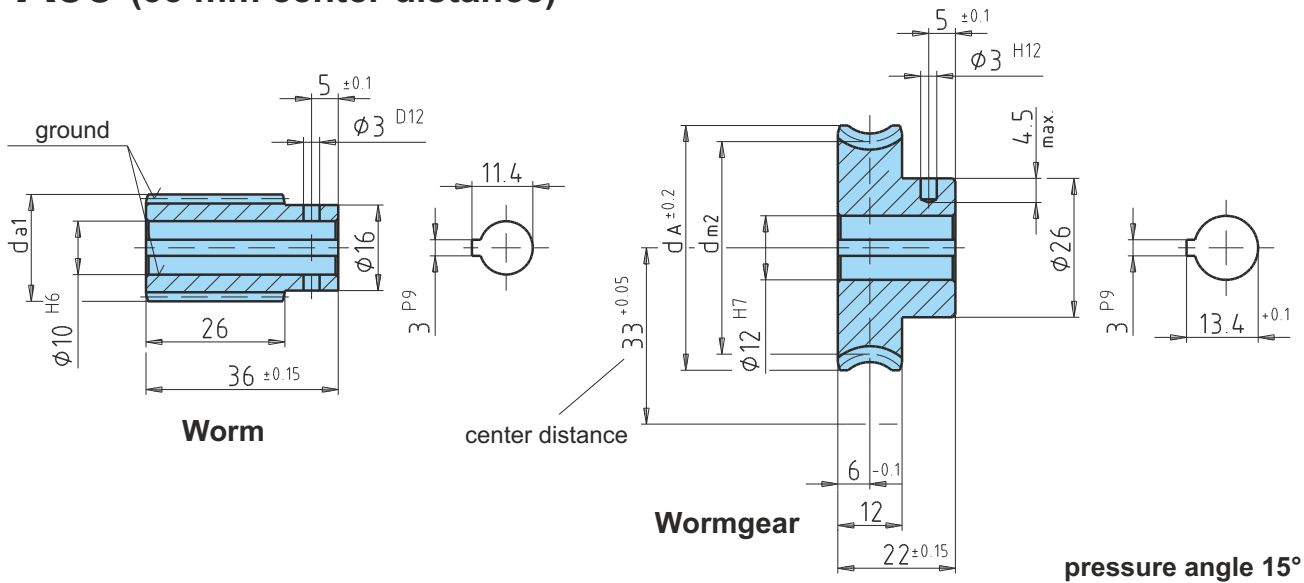

$i$  = gear ratio  
 $\alpha_m$  = lead angle  
 $m$  = module  
 $z_1$  = number of threads  
 $d_{m1}$  = pitch diameter (worm)

$d_{a1}$  = tip diameter (worm)  
 $z_2$  = No. of teeth  
 $d_{m2}$  = pitch diameter (worm gear)  
 $d_A$  = max. diameter (worm gear)  
 $T_2$  = output torque

MG = mineral grease  
 MO = mineral oil / synthetic grease  
 SO = synthetic oil

Catalog	worm						wormgear			$T_2$ [Nm] No.			
	$i$	$\alpha_m$	$m$	$z_1$	$d_{m1}$	$d_{a1}$	$z_2$	$d_{m2}$	$d_A$	Bronze MG	MO	SO	Phe- nolic
A33U3	3.5:1	25°57'	1.75	6	24	27.5	21	42	47	10.1	12.1	15.1	4.0
A33U5	5:1	20°50'	2	4	22.5	26.5	20	43.5	49	10.6	12.7	15.9	4.2
A33U7	7:1	15°32'	1.5	4	22.4	25.4	28	43.6	48	12.2	14.6	18.3	4.9
A33U10	10:1	13°10'	1.5	3	19.75	22.75	30	46.25	51	13.3	16	19.9	5.3
A33U11	11.33:1	10°42'	1.3	3	21	23.6	34	45	49.2	13.3	16	19.9	5.3
A33U12	12:1	11°14'	1.9	2	19.5	23.3	24	46.5	52	13.5	16.2	20.2	5.4
A33U14	14:1	7°20'	1.5	2	23.5	26.5	28	42.5	47	11.4	13.7	17.1	4.6
A33U15	15:1	8°25'	1.5	2	20.5	23.5	30	45.5	50	13	15.6	19.5	5.2
A33U16	16:1	10°1'	1.5	2	17.24	20.24	32	48.76	53	14	16.8	21	5.6
A33U17	17:1	9°3'	1.4	2	17.8	20.6	34	48.2	52.5	14.2	17	21.3	5.7
A33U18	18:1	6°57'	1.25	2	20.65	23.15	36	45.35	49.2	12.6	15.1	18.9	5.0
A33U20	20:1	6°43'	1.15	2	19.66	21.96	40	46.34	50.5	12.7	15.2	19	5.1
A33U24	24:1	5°27'	1.9	1	20	23.8	24	46	51	13.2	15.8	19.8	5.3
A33U28	28:1	3°36'	1.5	1	23.9	26.9	28	42.1	46.6	11.2	13.4	16.8	4.5
A33U30	30:1	4°8'	1.5	1	20.85	23.85	30	45.15	50	12.7	15.2	19	5.1
A33U32	32:1	4°50'	1.5	1	17.8	20.8	32	48.2	52.5	13.5	16.2	20.2	5.4
A33U38	38:1	3°55'	1.25	1	18.26	20.76	38	47.74	51.6	13.9	16.7	20.8	5.6
A33U50	50:1	2°27'	0.9	1	21	22.8	50	45	48	10	12	15	4.0
A33U56	56:1	2°10'	0.8	1	21.15	22.75	56	44.85	48	10.1	12.1	15.1	4.0
A33U60	60:1	2°33'	0.8	1	17.96	19.56	60	48.04	51.5	11.4	13.7	17.1	4.6
A33U72	72:1	1°30'	0.6	1	22.8	24	72	43.2	46	8.4	10.1	12.6	3.4
A33U75	75:1	1°41'	0.6	1	20.5	21.7	75	45.5	48	9	10.8	13.5	3.6

All worms and worm gears stocked right hand only, worm made of case hardened and ground steel (HV 620 - 700). Worm gear made of CuZn37Mn3Al2PbSi-S40 or at request of plastic or Hgw 2083.

Subject to technical changes

METRIC

# A35 (35 mm center distance)

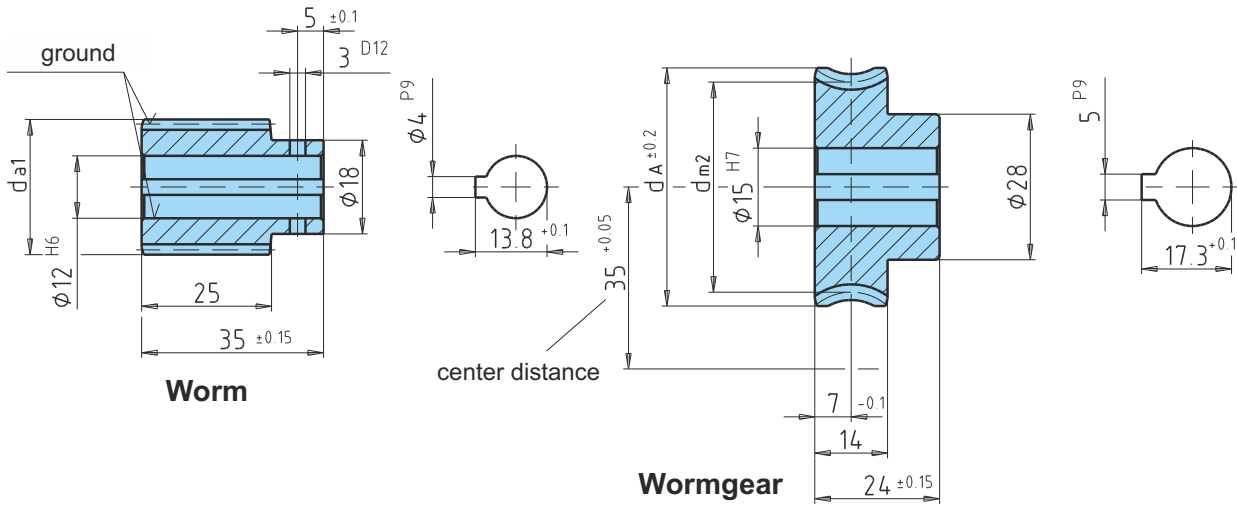

pressure angle 15°

$i$  = gear ratio  
 $\alpha_m$  = lead angle  
 $m$  = module  
 $z_1$  = number of threads  
 $d_{m1}$  = pitch diameter (worm)

$d_{a1}$  = tip diameter (worm)  
 $z_2$  = No. of teeth  
 $d_{m2}$  = pitch diameter (worm gear)  
 $d_A$  = max. diameter (worm gear)  
 $T_2$  = output torque

MG = mineral grease  
 MO = mineral oil / synthetic grease  
 SO = synthetic oil

Catalog				worm			wormgear			T <sub>2</sub> [Nm] No. Bronze		
	i	$\alpha_m$	m	$z_1$	$d_{m1}$	$d_{a1}$	$z_2$	$d_{m2}$	$d_A$	MG	MO	SO
A35U3*	2.78:1	31°01'	1.5	9	26.2	29.2	25	43.8	46.76	6.6	8.2	10.2
A35U5	5:1	22°52'	1.75	5	22.52	26.02	25	47.48	53	15.3	18.4	22.9
A35U7	7.25:1	13°47'	1.5	4	25.18	28.18	29	44.82	50	14.7	17.6	22
A35U8	8:1	14°25'	1.9	3	22.89	26.69	24	47.11	53	16.7	20	25
A35U10	10:1	10°43'	1.5	3	24.2	27.2	30	45.8	51	16	19.2	24
A35U11	11:1	10°32'	1.4	3	22.98	25.78	33	47.02	52	16.7	20	25
A35U12	12:1	9°11'	1.9	2	23.8	27.6	24	46.2	52	16.1	19.3	24
A35U15	15:1	7°	1.5	2	24.62	27.62	30	45.38	50	15.3	18.4	22.9
A35U20	20:1	5°33'	1.15	2	23.78	26.08	40	46.22	50.5	14.8	17.8	22.2
A35U25	25:1	4°9'	0.9	2	24.87	26.67	50	45.13	49	12.9	15.5	19.3
A35U30	30:1	3°27'	1.5	1	24.92	27.92	30	45.08	50	15	18	22.5
A35U35	35:1	3°51'	1.4	1	20.85	23.65	35	49.15	53	17.1	20.5	25.6
A35U40	40:1	2°45'	1.15	1	23.91	26.21	40	46.09	50.5	14.7	17.6	22
A35U50	50:1	2°4'	0.9	1	24.93	26.73	50	45.07	49	12.9	15.5	19.3
A35U58	58:1	2°21'	0.85	1	20.65	22.35	58	49.35	53	14.5	17.4	21.7
A35U90	90:1	1°9'	0.5	1	25	26	90	45	49	9.1	10.9	13.6

\* The worm gear of the A35U3 gear set can also be delivered as a crossed helical gear, pressure angle 20°.

All worms and worm gears stocked right hand only, worm made of case hardened and ground steel (HV 620 - 700). Worm gear made of CuZn37Mn3Al2PbSi-S40 or at request of plastic or Hgw 2083.



## A40 (40 mm center distance)

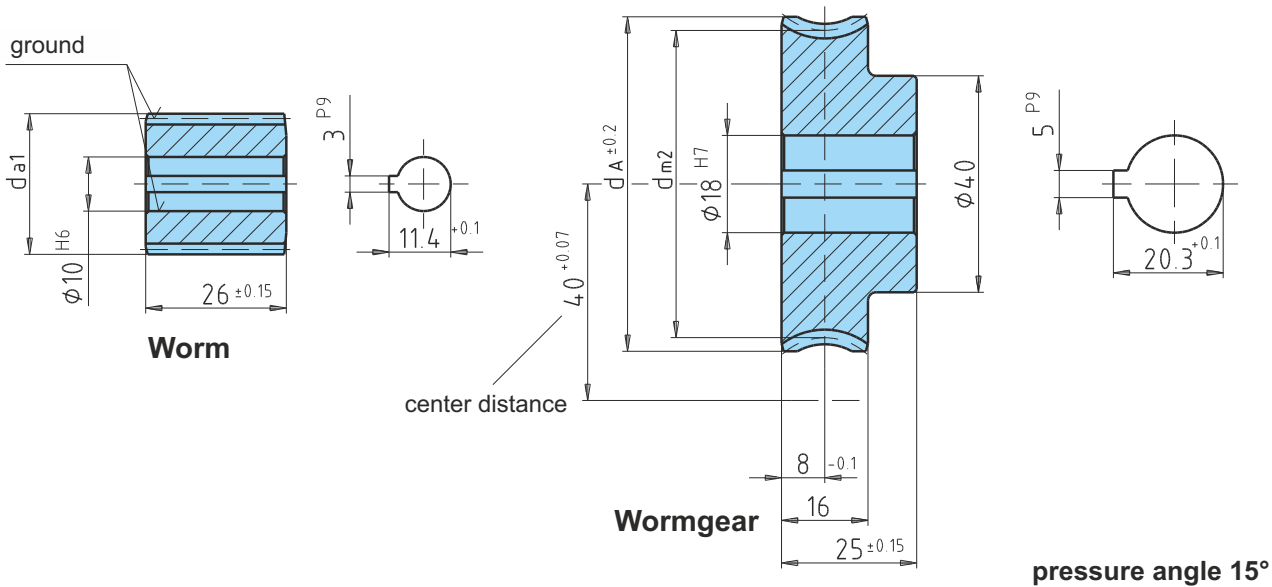

$i$  = gear ratio  
 $\alpha_m$  = lead angle  
 $m$  = module  
 $z_1$  = number of threads  
 $d_{m1}$  = pitch diameter (worm)

$d_{a1}$  = tip diameter (worm)  
 $z_2$  = No. of teeth  
 $d_{m2}$  = pitch diameter (worm gear)  
 $d_A$  = max. diameter (worm gear)  
 $T_2$  = output torque

MG = mineral grease  
 MO = mineral oil / synthetic grease  
 SO = synthetic oil

Catalog	worm			worm gear			$T_2$ [Nm] No. Bronze					
	$i$	$\alpha_m$	$m$	$z_1$	$d_{m1}$	$d_{a1}$	$z_2$	$d_{m2}$	$d_A$	MG	MO	SO
A40U7	6.75:1	21°19'	2	4	22	26	27	58	64	29.5	35.4	44.2
A40U8	8:1	16°35'	2.25	3	23.64	28.14	24	56.36	62.5	27.5	33	41.2
A40U10	10:1	16°1'	1.9	3	20.66	24.46	30	59.34	65	29.5	35.4	44.2
A40U12	12:1	10°21'	1.5	3	25.05	28.05	36	54.95	60	25.2	30.2	37.8
A40U15	15:1	9°53'	1.9	2	22.14	25.94	30	57.86	64	28	33.6	42
A40U20	20:1	8°59'	1.5	2	19.2	22.2	40	60.8	66	28.9	34.6	43.3
A40U25	25:1	5°58'	1.15	2	22.15	24.45	50	57.85	62	24.4	29.2	36.6
A40U28	28:1	4°47'	2	1	24	28	28	56	61.5	28.4	34	42.6
A40U30	30:1	5°50'	2	1	19.68	23.68	30	60.32	66	30.1	36.1	45.1
A40U35	35:1	5°26'	1.75	1	18.48	21.98	35	61.52	67	31	37.2	46.5
A40U36	36:1	3°19'	1.5	1	25.91	28.91	36	54.09	59	23.9	28.6	35.8
A40U40	40:1	4°20'	1.5	1	19.83	22.83	40	60.17	65	28.3	33.9	42.4
A40U50	50:1	4°8'	1.25	1	17.3	19.8	50	62.7	68	27	32.4	40.5
A40U56	56:1	2°23'	1	1	24	26	56	56	59	21.9	26.2	32.8
A40U60	60:1	1°59'	0.9	1	25.92	27.72	60	54.08	57.5	19.3	23.1	28.9
A40U70	70:1	3°3'	0.9	1	16.91	18.71	70	63.09	67	24.1	28.9	36.1
A40U75	75:1	1°48'	0.75	1	23.75	25.25	75	56.26	60	18.8	22.5	28.2
A40U80	80:1	2°10'	0.75	1	19.9	21.4	80	60.1	64	20.1	24.1	30.1
A40U90	90:1	2°22'	0.7	1	16.95	18.35	90	63.05	67	19.1	22.9	28.6

All worms and worm gears stocked right hand only, worm made of case hardened and ground steel (HV 620 - 700). Worm gear made of CuZn37Mn3Al2PbSi-S40 or at request of plastic or Hgw 2083.

Subject to technical changes

METRIC

## A50 (50 mm center distance)

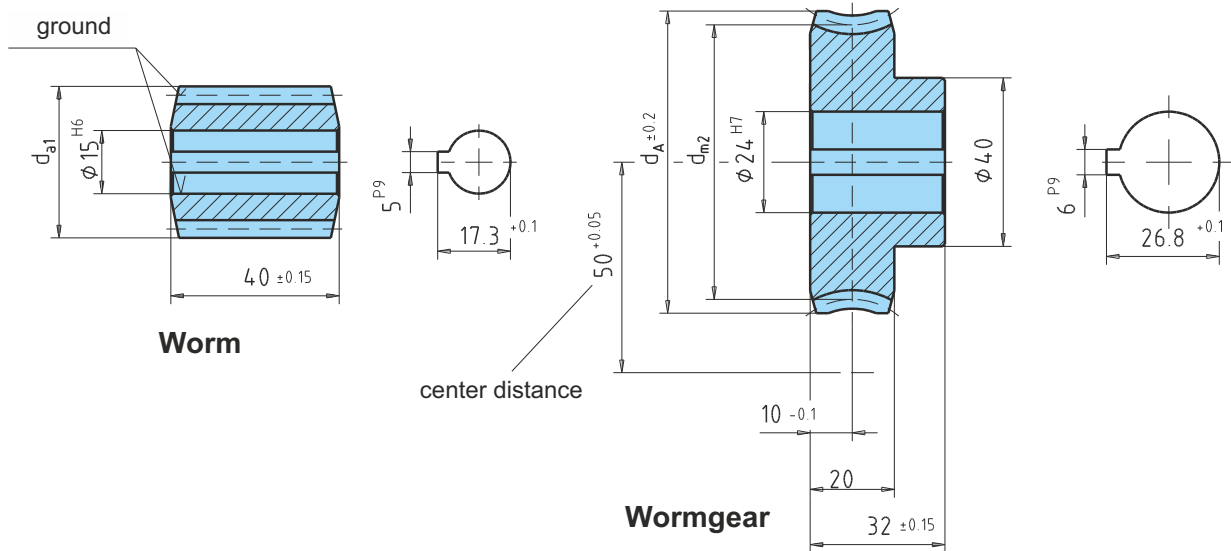

pressure angle 15°

$i$  = gear ratio  
 $\alpha_m$  = lead angle  
 $m$  = module  
 $z_1$  = number of threads  
 $d_{m1}$  = pitch diameter (worm)

$d_{a1}$  = tip diameter (worm)  
 $z_2$  = No. of teeth  
 $d_{m2}$  = pitch diameter (worm gear)  
 $d_A$  = max. diameter (worm gear)  
 $T_2$  = output torque

MG = mineral grease  
 MO = mineral oil / synthetic grease  
 SO = synthetic oil

Catalog	$i$	$\alpha_m$	$m$	$z_1$	worm		wormgear			T <sub>2</sub> [Nm] No. Bronze		
					$d_{m1}$	$d_{a1}$	$z_2$	$d_{m2}$	$d_A$	MG	MO	SO
A50U4	4.25:1	25°51'	3.5	4	32.1	39.1	17	67.9	77	34	40.8	51
A50U6	6:1	19°17'	3.5	3	31.8	38.8	18	68.2	77	52	62.4	78
A50U9	8.66:1	13°52'	2.5	3	31.29	36.29	26	68.71	77	64.3	77.1	96.4
A50U12	12:1	10°23'	2.75	2	30.5	36	24	69.5	77	66.4	79.6	99.6
A50U14	13.5:1	9°38'	2.5	2	29.9	34.9	27	70.1	77	62.8	75.4	94.2
A50U19	19:1	6°17'	3.5	1	32	39	19	68	77	78.2	93.8	117.3
A50U23	23:1	5°38'	3	1	30.58	36.58	23	69.42	77	71.1	85.3	106.6
A50U27	27:1	4°40'	2.5	1	30.73	35.73	27	69.27	77	64.5	77.4	96.7
A50U35	35:1	3°51'	2	1	29.78	33.78	35	70.22	77	56.7	68	85
A50U46	46:1	2°47'	1.5	1	30.85	33.85	46	69.15	74	50.6	60.7	75.9
A50U55	55:1	2°19'	1.25	1	30.9	33.4	55	69.1	74	46.2	55.4	69.3
A50U69	69:1	1°51'	1	1	30.9	32.9	69	69.1	74	41.4	49.6	62.8

All worms and worm gears stocked right hand only, worm made of case hardened and ground steel (HV 620 - 700). Worm gear made of CuZn37Mn3Al2PbSi-S40 or at request of plastic or Hgw 2083.



## A50 (50 mm center distance)

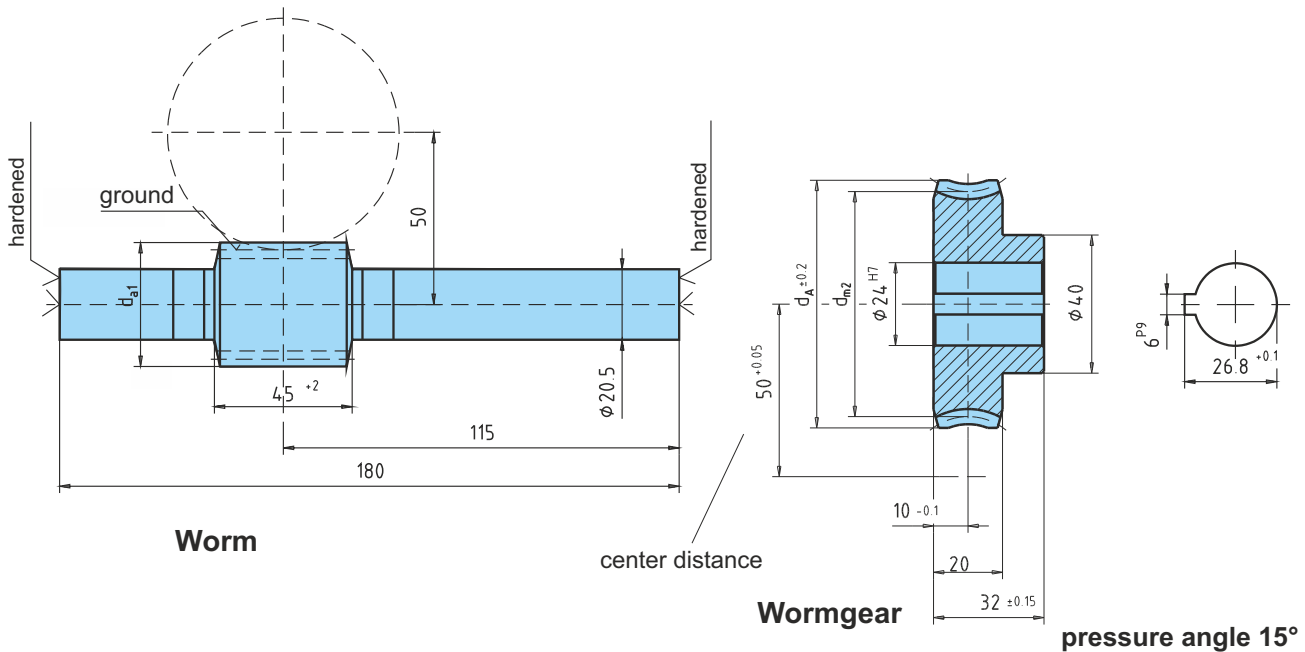

$i$  = gear ratio  
 $\alpha_m$  = lead angle  
 $m$  = module  
 $z_1$  = number of threads  
 $d_{m1}$  = pitch diameter (worm)

$d_{a1}$  = tip diameter (worm)  
 $z_2$  = No. of teeth  
 $d_{m2}$  = pitch diameter (worm gear)  
 $d_A$  = max. diameter (worm gear)  
 $T_2$  = output torque

MG = mineral grease  
 MO = mineral oil / synthetic  
 grease  
 SO = synthetic oil

Catalog				worm			wormgear			$T_2$ [Nm] No. Bronze		
	$i$	$\alpha_m$	$m$	$z_1$	$d_{m1}$	$d_{a1}$	$z_2$	$d_{m2}$	$d_A$	MG	MO	SO
A50U4	4.25:1	25°51'	3.5	4	32.1	39.1	17	67.9	77	34	40.8	51
A50U6	6:1	19°17'	3.5	3	31.8	38.8	18	68.2	77	52	62.4	78
A50U9	8.66:1	13°52'	2.5	3	31.29	36.29	26	68.71	77	64.3	77.1	96.4
A50U12	12:1	10°23'	2.75	2	30.5	36	24	69.5	77	66.4	79.6	99.6
A50U14	13.5:1	9°38'	2.5	2	29.9	34.9	27	70.1	77	62.8	75.4	94.2
A50U19	19:1	6°17'	3.5	1	32	39	19	68	77	78.2	93.8	117.3
A50U23	23:1	5°38'	3	1	30.58	36.58	23	69.42	77	71.1	85.3	106.6
A50U27	27:1	4°40'	2.5	1	30.73	35.73	27	69.27	77	64.5	77.4	96.7
A50U35	35:1	3°51'	2	1	29.78	33.78	35	70.22	77	56.7	68	85
A50U46	46:1	2°47'	1.5	1	30.85	33.85	46	69.15	74	50.6	60.7	75.9
A50U55	55:1	2°19'	1.25	1	30.9	33.4	55	69.1	74	46.2	55.4	69.3
A50U69	69:1	1°51'	1	1	30.9	32.9	69	69.1	74	41.4	49.6	62.8

All worms and worm gears stocked right hand only, worm made of case hardened and ground steel (HV 620 - 700), shafts not hardened. Worm gear made of CuZn37Mn3Al2PbSi-S40 or at request of plastic or Hgw 2083.

Subject to technical changes

METRIC

# A53 (53 mm center distance)

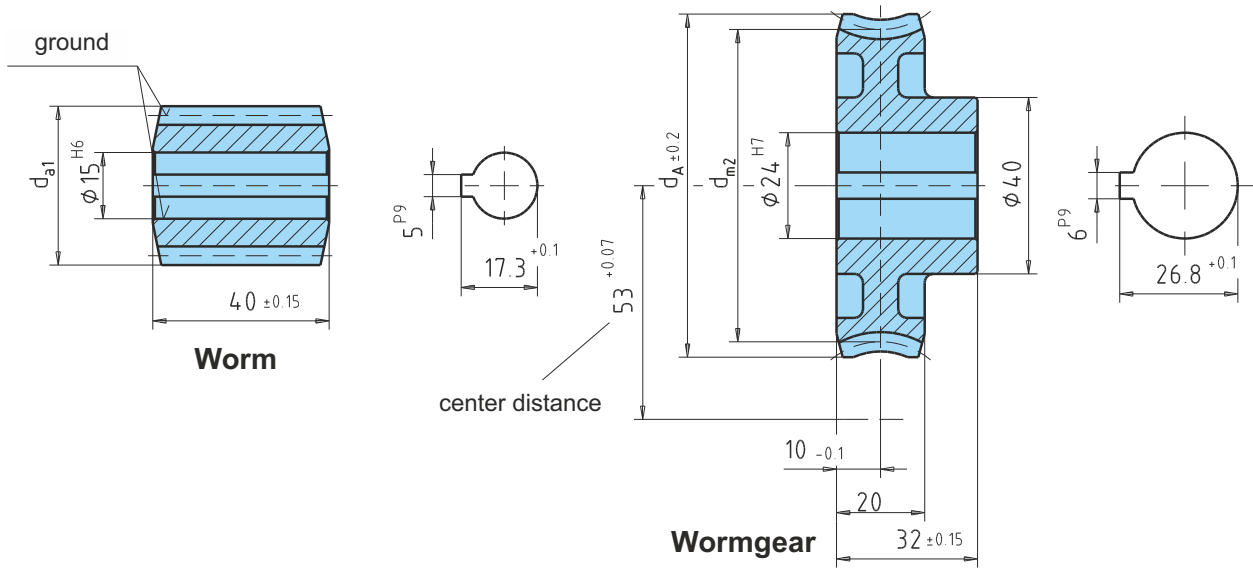

pressure angle 15°

i = gear ratio  
 $\alpha_m$  = lead angle  
 m = module  
 $z_1$  = number of threads  
 $d_{m1}$  = pitch diameter (worm)

$d_{a1}$  = tip diameter (worm)  
 $z_2$  = No. of teeth  
 $d_{m2}$  = pitch diameter (worm gear)  
 $d_A$  = max. diameter (worm gear)  
 $T_2$  = output torque

MG = mineral grease  
 MO = mineral oil / synthetic grease  
 SO = synthetic oil

Catalog	i	$\alpha_m$	m	worm			wormgear			T <sub>2</sub> [Nm] No. Bronze		
				$z_1$	$d_{m1}$	$d_{a1}$	$z_2$	$d_{m2}$	$d_A$	MG	MO	SO
A53U5	4.75:1	25°51'	3.5	4	32.1	39.1	19	73.9	83	45	54	67.5
A53U7	6.67:1	19°17'	3.5	3	31.8	38.8	20	74.2	84	67	81	101
A53U10	9.67:1	13°52'	2.5	3	31.29	36.29	29	74.71	82	77	93	116
A53U14	13.5:1	10°23'	2.75	2	30.5	36	27	75.5	84	80	96	120
A53U15	15:1	9°38'	2.5	2	29.9	34.9	30	76.1	83	75	90	113
A53U21	21:1	6°17'	3.5	1	32	39	21	74	83	94	113	141
A53U25	25:1	5°38'	3	1	30.58	36.58	25	75.42	84	84	101	127
A53U28	28:1	3°59'	2.5	1	36	41	28	70	77.5	87	104	130
A53U30	30:1	4°40'	2.5	1	30.73	35.73	30	75.27	83	77	93	116
A53U38	38:1	3°51'	2	1	29.78	33.78	38	76.21	83	68	81	102
A53U50	50:1	2°47'	1.5	1	30.85	33.85	50	75.15	81	60	72	90
A53U60	60:1	2°19'	1.25	1	30.9	33.4	60	75.1	80	55	66	82
A53U75	75:1	1°51'	1	1	30.9	32.9	75	75.1	78	49	59	74

All worms and worm gears stocked right hand only, worm made of case hardened and ground steel (HV 620 - 700). Worm gear made of CuZn37Mn3Al2PbSi-S40 or at request of plastic or Hgw 2083.



## A63 (63 mm center distance)

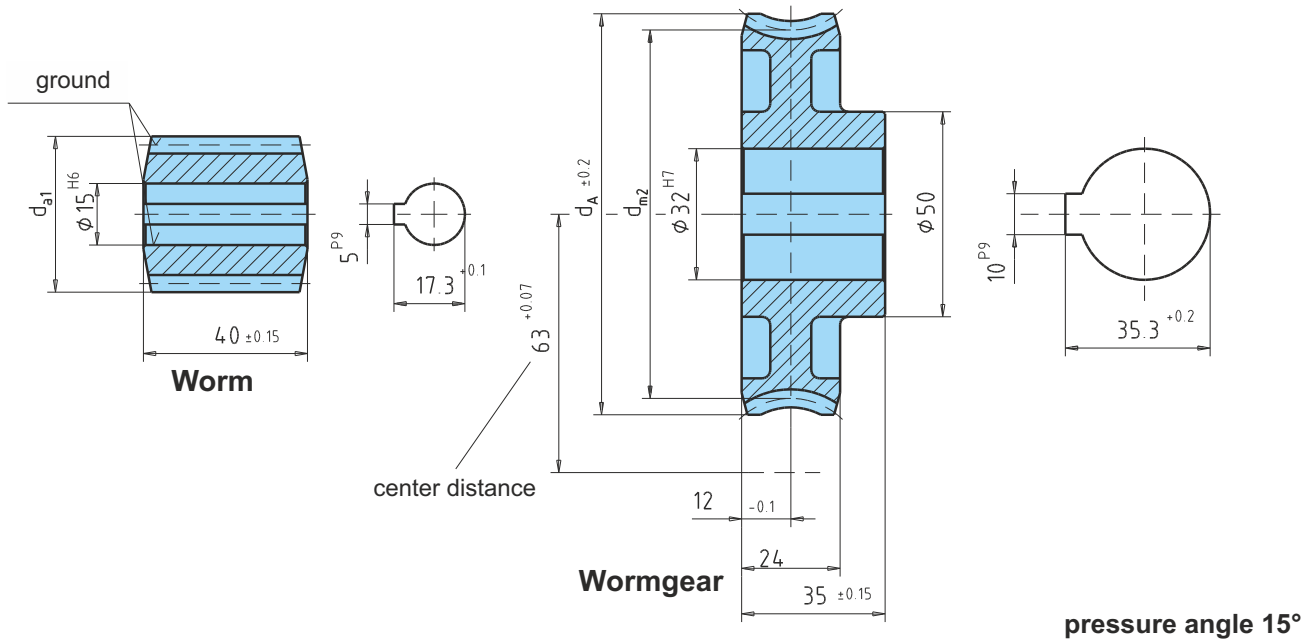

$i$  = gear ratio  
 $\alpha_m$  = lead angle  
 $m$  = module  
 $z_1$  = number of threads  
 $d_{m1}$  = pitch diameter (worm)

$d_{a1}$  = tip diameter (worm)  
 $z_2$  = No. of teeth  
 $d_{m2}$  = pitch diameter (worm gear)  
 $d_A$  = max. diameter (worm gear)  
 $T_2$  = output torque  
 MG = mineral grease

MO = mineral oil / synthetic grease  
 SO = synthetic oil

Catalog	i	$\alpha_m$	m	worm			wormgear			T <sub>2</sub> [Nm] No. Bronze		
				z <sub>1</sub>	d <sub>m1</sub>	d <sub>a1</sub>	z <sub>2</sub>	d <sub>m2</sub>	d <sub>A</sub>	MG	MO	SO
<b>A63U6</b>	6:1	25°51'	3.5	4	32.1	39.1	24	93.9	104	89	107	134
<b>A63U12</b>	12:1	13°52'	2.5	3	31.29	36.29	36	94.71	104	141	170	212
<b>A63U19</b>	19:1	10°8'	2.5	2	28.4	33.4	38	97.6	104	133	159	199
<b>A63U26</b>	26:1	6°17'	3.5	1	32	39	26	94	104	172	206	258
<b>A63U34</b>	34:1	5°9'	2.75	1	30.6	36.1	34	95.4	104	148	178	222
<b>A63U48</b>	48:1	3°51'	2	1	29.78	33.78	48	96.22	104	125	150	187
<b>A63U63</b>	63:1	2°47'	1.5	1	30.85	33.85	63	95.15	101	111	133	166
<b>A63U70</b>	70:1	1°59'	1.25	1	36.1	38.6	70	89.9	97	112	135	169

All worms and worm gears stocked right hand only, worm made of case hardened and ground steel (HV 620 - 700). Worm gear made of CuZn37Mn3Al2PbSi-S40 or at request of plastic or Hgw 2083.

Subject to technical changes

METRIC

**A63 (63 mm center distance)**

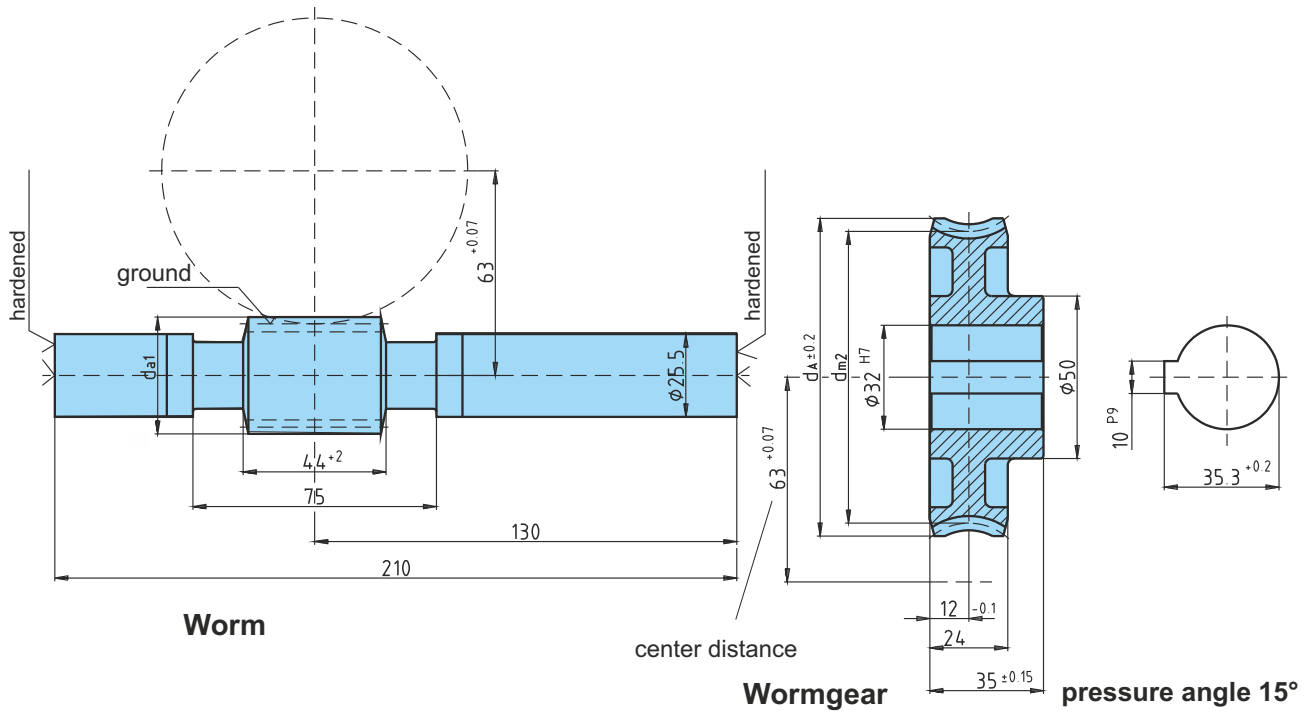

$i$  = gear ratio  
 $\alpha_m$  = lead angle  
 $m$  = module  
 $z_1$  = number of threads  
 $d_{m1}$  = pitch diameter (worm)

$d_{a1}$  = tip diameter (worm)  
 $z_2$  = No. of teeth  
 $d_{m2}$  = pitch diameter (worm gear)  
 $d_A$  = max. diameter (worm gear)  
 $T_2$  = output torque

MG = mineral grease  
 MO = mineral oil / synthetic grease  
 SO = synthetic oil

Catalog	i	m	m	worm			wormgear			T <sub>2</sub> [Nm] No. Bronze		
				z <sub>1</sub>	d <sub>m1</sub>	d <sub>a1</sub>	z <sub>2</sub>	d <sub>m2</sub>	d <sub>A</sub>	MG	MO	SO
A63U6	6:1	25°51'	3.5	4	32.1	39.1	24	93.9	104	89	107	134
A63U12	12:1	13°52'	2.5	3	31.29	36.29	36	94.71	104	141	170	212
A63U19	19:1	10°8'	2.5	2	28.4	33.4	38	97.6	104	133	159	199
A63U26	26:1	6°17'	3.5	1	32	39	26	94	104	172	206	258
A63U34	34:1	5°9'	2.75	1	30.6	36.1	34	95.4	104	148	178	222
A63U48	48:1	3°51'	2	1	29.78	33.78	48	96.22	104	125	150	187
A63U63	63:1	2°47'	1.5	1	30.85	33.85	63	95.15	101	111	133	166
A63U70	70:1	1°59'	1.25	1	36.1	38.6	70	89.9	97	112	135	169

All worms and worm gears stocked right hand only, worm made of case hardened and ground steel (HV 620 - 700), shafts not hardened. Worm gear made of CuZn37Mn3Al2PbSi-S40 or at request of plastic or Hgw 2083.

METRIC

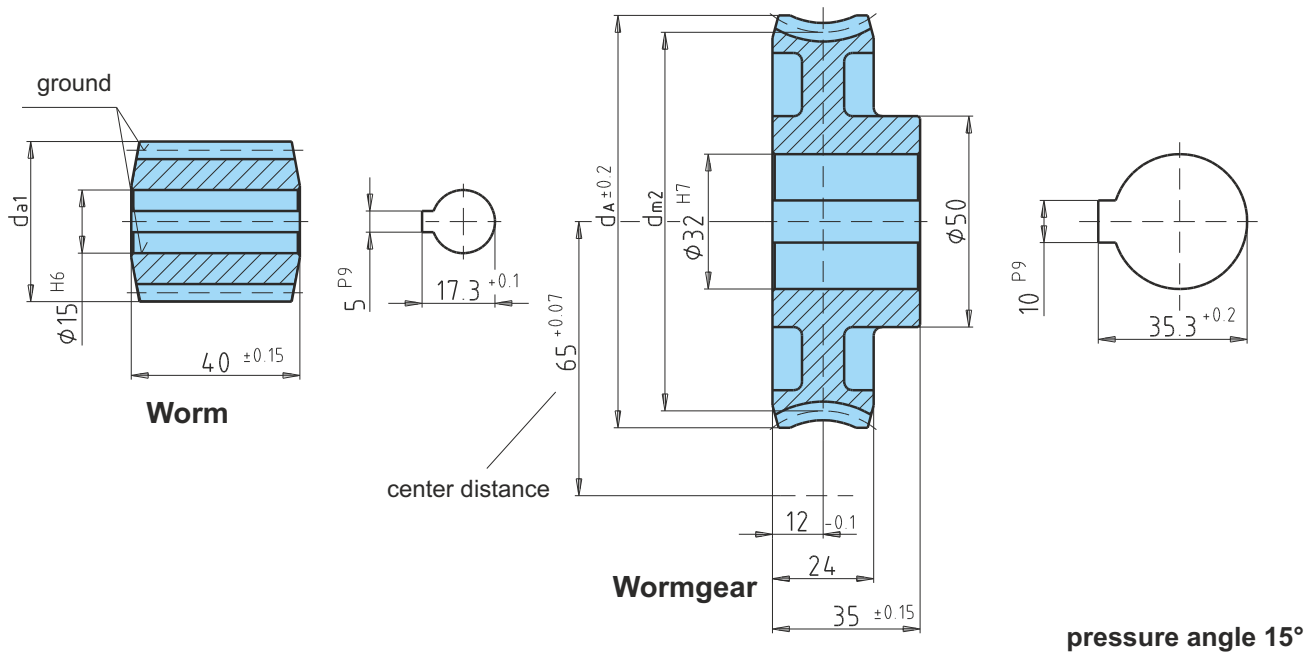
**A65 (65 mm center distance)**

$i$  = gear ratio  
 $\alpha_m$  = lead angle  
 $m$  = module  
 $z_1$  = number of threads  
 $d_{m1}$  = pitch diameter (worm)

$d_{a1}$  = tip diameter (worm)  
 $z_2$  = No. of teeth  
 $d_{m2}$  = pitch diameter (worm gear)  
 $d_A$  = max. diameter (worm gear)  
 $T_2$  = output torque

MG = mineral grease  
 MO = mineral oil / synthetic grease  
 SO = synthetic oil

Catalog	i	$\alpha_m$	m	$z_1$	worm			wormgear			T <sub>2</sub> [Nm] No. Bronze		
					$d_{m1}$	$d_{a1}$	$z_2$	$d_{m2}$	$d_A$	MG	MO	SO	
A65U6	6.25:1	25°51'	3.5	4	32.1	39.1	25	97.9	108	101	121	151	
A65U13	12.66:1	13°52'	2.5	3	31.29	36.29	38	98.71	108	156	187	234	
A65U20	20:1	10°8'	2.5	2	28.4	33.4	40	101.6	108	146	176	220	
A65U28	28:1	6°17'	3.5	1	32	39	28	98	108	192	230	288	
A65U36	36:1	5°9'	2.75	1	30.6	36.1	36	99.4	108	164	197	246	
A65U50	50:1	3°51'	2	1	29.78	33.78	50	100.22	108	137	164	205	
A65U66	66:1	2°47'	1.5	1	30.85	33.85	66	99.15	107	122	146	183	
A65U75	75:1	1°59'	1.25	1	36.1	38.6	75	93.9	100	125	150	188	

All worms and worm gears stocked right hand only, worm made of case hardened and ground steel (HV 620 - 700). Worm gear made of CuZn37Mn3Al2PbSi-S40 or at request of plastic or Hgw 2083.

Subject to technical changes

METRIC

## A80 (80 mm center distance)

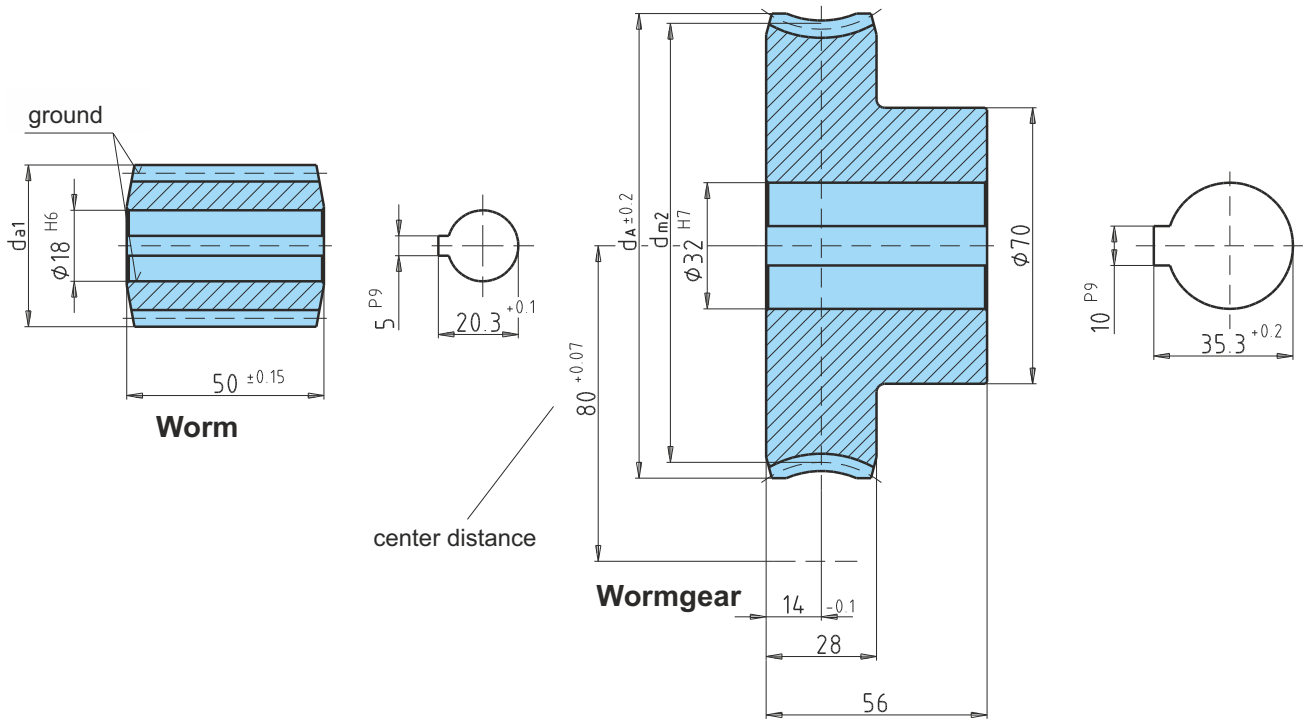

pressure angle 15°

$i$  = gear ratio  
 $\alpha_m$  = lead angle  
 $m$  = module  
 $z_1$  = number of threads  
 $d_{m1}$  = pitch diameter (worm)

$d_{a1}$  = tip diameter (worm)  
 $z_2$  = No. of teeth  
 $d_{m2}$  = pitch diameter (worm gear)  
 $d_A$  = max. diameter (worm gear)  
 $T_2$  = output torque  
 MG = mineral grease

MO = mineral oil / synthetic grease  
 SO = synthetic oil

Catalog	$i$	$\alpha_m$	$m$	worm			wormgear			$T_2$ [Nm] No. Bronze		
				$z_1$	$d_{m1}$	$d_{a1}$	$z_2$	$d_{m2}$	$d_A$	MG	MO	SO
<b>A80U7</b>	6.75:1	23°35'	4	4	40	48	27	120	132	150	180	225
<b>A80U12</b>	12:1	16°36'	2.5	4	35	40	48	125	132,5	243	290	365
<b>A80U20</b>	20:1	8°58'	3	2	38.5	44.5	40	121.5	130,5	290	348	435
<b>A80U30</b>	30:1	5°44'	4	1	40	48	30	120	132,5	348	417	522
<b>A80U50</b>	50:1	4°6'	2.5	1	35	40	50	125	132,5	248	297	372
<b>A80U80</b>	80:1	2°9'	1.5	1	40	43	80	120	124,5	213	255	320

All worms and worm gears stocked right hand only, worm made of case hardened and ground steel (HV 620 - 700). Worm gear made of CuZn37Mn3Al2PbSi-S40 or at request of plastic or Hgw 2083.



## A80 (80 mm center distance)

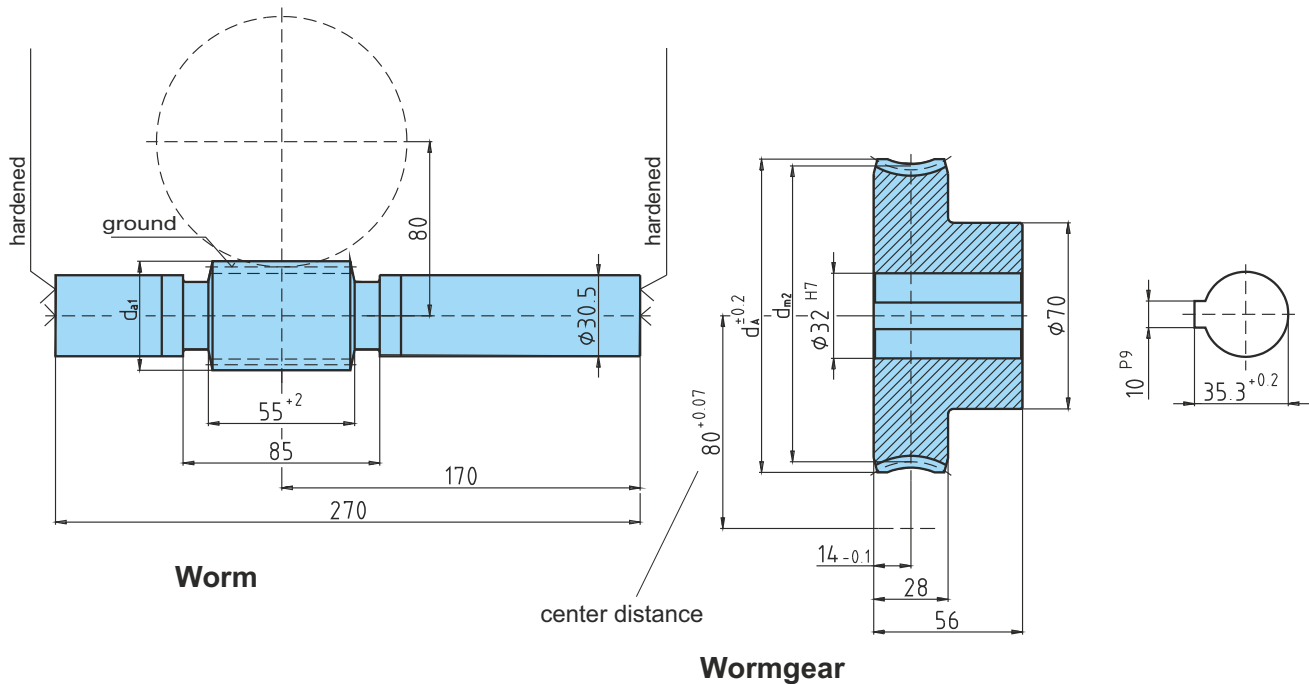

pressure angle 15°

$i$  = gear ratio  
 $\alpha_m$  = lead angle  
 $m$  = module  
 $z_1$  = number of threads  
 $d_{m1}$  = pitch diameter (worm)

$d_{a1}$  = tip diameter (worm)  
 $z_2$  = No. of teeth  
 $d_{m2}$  = pitch diameter (worm gear)  
 $d_A$  = max. diameter (worm gear)  
 $T_2$  = output torque

MG = mineral grease  
 MO = mineral oil / synthetic grease  
 SO = synthetic oil

Catalog	$i$	$\alpha_m$	$m$	worm			wormgear			$T_2$ [Nm] No. Bronze		
				$z_1$	$d_{m1}$	$d_{a1}$	$z_2$	$d_{m2}$	$d_A$	MG	MO	SO
A80U7	6.75:1	23°35'	4	4	40	48	27	120	132	150	180	225
A80U12	12:1	16°36'	2.5	4	35	40	48	125	132,5	243	290	365
A80U20	20:1	8°58'	3	2	38.5	44.5	40	121.5	130,5	290	348	435
A80U30	30:1	5°44'	4	1	40	48	30	120	132,5	348	417	522
A80U50	50:1	4°6'	2.5	1	35	40	50	125	132,5	248	297	372
A80U80	80:1	2°9'	1.5	1	40	43	80	120	124,5	213	255	320

All worms and worm gears stocked right hand only, worm made of case hardened and ground steel (HV 620 - 700), shafts not hardened.

Worm gear made of CuZn37Mn3Al2PbSi-S40 or at request of plastic or Hgw 2083.

Subject to technical changes

## Efficiency factors

Efficiency factors depending on input (worm) speed and lubrication (mineral grease 'MG', mineral oil 'MO' or synthetic grease, synthetic oil 'SO')

### A17

	n <sub>1</sub> = 2800 rpm			n <sub>1</sub> = 1400 rpm			n <sub>1</sub> = 950 rpm			n <sub>1</sub> = 700 rpm			n <sub>1</sub> = 500 rpm		
	MG	MO	SO	MG	MO	SO	MG	MO	SO	MG	MO	SO	MG	MO	SO
<b>U2</b>	0,8	0,84	0,87	0,77	0,81	0,85	0,76	0,8	0,84	0,76	0,8	0,84	0,76	0,8	0,84
<b>U4</b>	0,75	0,79	0,83	0,72	0,76	0,8	0,7	0,75	0,79	0,7	0,74	0,79	0,7	0,74	0,79
<b>U5</b>	0,74	0,79	0,82	0,71	0,76	0,8	0,7	0,75	0,79	0,69	0,74	0,79	0,69	0,74	0,79
<b>U7</b>	0,68	0,73	0,77	0,64	0,7	0,75	0,63	0,68	0,73	0,62	0,68	0,73	0,62	0,68	0,73
<b>U9</b>	0,61	0,66	0,71	0,57	0,63	0,68	0,55	0,61	0,66	0,54	0,6	0,66	0,54	0,6	0,66
<b>U10</b>	0,64	0,69	0,74	0,6	0,66	0,71	0,59	0,65	0,7	0,59	0,64	0,7	0,59	0,64	0,7
<b>U15</b>	0,54	0,6	0,65	0,51	0,57	0,62	0,49	0,55	0,61	0,49	0,55	0,61	0,49	0,55	0,61
<b>U25</b>	0,42	0,48	0,53	0,38	0,44	0,5	0,37	0,43	0,48	0,37	0,42	0,48	0,37	0,42	0,48
<b>U30</b>	0,37	0,43	0,49	0,34	0,4	0,45	0,33	0,38	0,44	0,33	0,38	0,44	0,33	0,38	0,44
<b>U40</b>	0,26	0,3	0,36	0,23	0,27	0,32	0,22	0,26	0,31	0,21	0,25	0,3	0,21	0,25	0,3
<b>U50</b>	0,33	0,38	0,44	0,3	0,35	0,41	0,29	0,34	0,4	0,29	0,34	0,4	0,29	0,34	0,4
<b>U60</b>	0,26	0,31	0,36	0,24	0,28	0,33	0,23	0,27	0,32	0,23	0,27	0,32	0,23	0,27	0,32
<b>U75</b>	0,19	0,23	0,27	0,17	0,21	0,25	0,16	0,2	0,24	0,16	0,19	0,23	0,16	0,19	0,23
<b>U80</b>	0,21	0,25	0,3	0,19	0,23	0,27	0,18	0,22	0,26	0,18	0,22	0,26	0,18	0,22	0,26

### A22

	n <sub>1</sub> = 2800 rpm			n <sub>1</sub> = 1400 rpm			n <sub>1</sub> = 950 rpm			n <sub>1</sub> = 700 rpm			n <sub>1</sub> = 500 rpm		
	MG	MO	SO	MG	MO	SO	MG	MO	SO	MG	MO	SO	MG	MO	SO
<b>U3</b>	0,74	0,79	0,82	0,71	0,76	0,8	0,69	0,74	0,79	0,68	0,73	0,78	0,67	0,72	0,77
<b>U4</b>	0,75	0,79	0,83	0,72	0,76	0,8	0,7	0,75	0,79	0,69	0,74	0,78	0,68	0,73	0,77
<b>U7</b>	0,66	0,71	0,76	0,63	0,68	0,73	0,61	0,66	0,71	0,6	0,65	0,7	0,59	0,64	0,69
<b>U10,5</b>	0,57	0,63	0,68	0,53	0,59	0,65	0,51	0,57	0,63	0,5	0,56	0,62	0,49	0,55	0,61
<b>U21</b>	0,4	0,46	0,52	0,37	0,42	0,48	0,35	0,4	0,46	0,34	0,39	0,45	0,33	0,38	0,44
<b>U30</b>	0,34	0,39	0,45	0,3	0,35	0,41	0,29	0,34	0,39	0,27	0,32	0,38	0,27	0,32	0,37
<b>U40</b>	0,29	0,34	0,4	0,26	0,31	0,36	0,25	0,29	0,34	0,24	0,28	0,33	0,23	0,28	0,33

### A25

	n <sub>1</sub> = 2800 rpm			n <sub>1</sub> = 1400 rpm			n <sub>1</sub> = 950 rpm			n <sub>1</sub> = 700 rpm			n <sub>1</sub> = 500 rpm		
	MG	MO	SO	MG	MO	SO	MG	MO	SO	MG	MO	SO	MG	MO	SO
<b>U4</b>	0,76	0,8	0,84	0,73	0,77	0,81	0,71	0,76	0,8	0,7	0,75	0,79	0,69	0,74	0,78
<b>U5</b>	0,75	0,79	0,83	0,71	0,76	0,8	0,7	0,75	0,79	0,69	0,74	0,78	0,68	0,73	0,77
<b>U6,5</b>	0,7	0,74	0,79	0,66	0,71	0,76	0,64	0,7	0,75	0,63	0,68	0,73	0,62	0,67	0,72
<b>U10</b>	0,61	0,66	0,71	0,57	0,62	0,68	0,55	0,61	0,66	0,53	0,59	0,65	0,52	0,58	0,64
<b>U15</b>	0,53	0,59	0,64	0,49	0,55	0,61	0,47	0,53	0,59	0,46	0,52	0,58	0,45	0,51	0,57
<b>U20</b>	0,44	0,5	0,55	0,4	0,46	0,51	0,38	0,44	0,5	0,37	0,42	0,48	0,36	0,41	0,47
<b>U25</b>	0,3	0,36	0,41	0,27	0,32	0,38	0,26	0,3	0,35	0,25	0,29	0,34	0,23	0,28	0,33
<b>U30</b>	0,34	0,4	0,46	0,31	0,36	0,42	0,29	0,34	0,4	0,28	0,33	0,38	0,27	0,32	0,37
<b>U40</b>	0,31	0,36	0,42	0,28	0,33	0,38	0,26	0,31	0,37	0,25	0,3	0,35	0,25	0,29	0,35
<b>U50</b>	0,24	0,28	0,33	0,21	0,25	0,3	0,2	0,24	0,28	0,19	0,23	0,27	0,18	0,22	0,26

The stated values are approximate values

### Operative efficiency

Efficiency factors depending on input (worm) speed and lubrication (mineral grease 'MG', mineral oil 'MO' or synthetic grease, synthetic oil 'SO')

#### A31

	n <sub>1</sub> = 2800 rpm			n <sub>1</sub> = 1400 rpm			n <sub>1</sub> = 950 rpm			n <sub>1</sub> = 700 rpm			n <sub>1</sub> = 500 rpm		
	MG	MO	SO	MG	MO	SO	MG	MO	SO	MG	MO	SO	MG	MO	SO
<b>U2,5</b>	0,82	0,85	0,88	0,79	0,83	0,86	0,78	0,82	0,85	0,77	0,81	0,85	0,76	0,8	0,84
<b>U3</b>	0,81	0,85	0,87	0,78	0,82	0,86	0,77	0,81	0,85	0,76	0,8	0,84	0,75	0,79	0,83
<b>U4,28</b>	0,79	0,82	0,86	0,76	0,8	0,83	0,74	0,78	0,82	0,73	0,77	0,81	0,72	0,76	0,81
<b>U5</b>	0,78	0,82	0,85	0,75	0,79	0,83	0,73	0,78	0,82	0,72	0,77	0,81	0,71	0,76	0,8
<b>U6</b>	0,74	0,79	0,82	0,71	0,76	0,8	0,7	0,74	0,79	0,68	0,73	0,78	0,67	0,72	0,77
<b>U7</b>	0,75	0,79	0,83	0,72	0,77	0,81	0,71	0,75	0,8	0,69	0,74	0,79	0,69	0,74	0,78
<b>U8,33</b>	0,74	0,79	0,82	0,71	0,76	0,8	0,7	0,75	0,79	0,69	0,74	0,78	0,68	0,73	0,78
<b>U12</b>	0,69	0,74	0,78	0,65	0,7	0,75	0,64	0,69	0,74	0,62	0,68	0,73	0,62	0,67	0,72
<b>U15</b>	0,64	0,69	0,74	0,6	0,66	0,71	0,58	0,64	0,69	0,57	0,63	0,68	0,56	0,62	0,68
<b>U18</b>	0,59	0,65	0,7	0,56	0,61	0,67	0,54	0,6	0,65	0,53	0,58	0,64	0,52	0,58	0,63
<b>U20 *</b>	0,57	0,63	0,68	0,53	0,59	0,64	0,51	0,57	0,63	0,5	0,56	0,62	0,49	0,55	0,61
<b>U20 **</b>	0,59	0,64	0,69	0,55	0,61	0,66	0,53	0,59	0,64	0,52	0,58	0,63	0,51	0,57	0,63
<b>U22</b>	0,53	0,59	0,64	0,49	0,55	0,61	0,47	0,53	0,59	0,46	0,52	0,58	0,45	0,51	0,57
<b>U23</b>	0,56	0,61	0,67	0,52	0,58	0,63	0,5	0,56	0,61	0,49	0,55	0,6	0,48	0,54	0,6
<b>U24</b>	0,48	0,54	0,59	0,44	0,49	0,55	0,42	0,48	0,54	0,4	0,46	0,52	0,39	0,45	0,51
<b>U25</b>	0,49	0,55	0,61	0,45	0,51	0,57	0,44	0,5	0,55	0,42	0,48	0,54	0,41	0,47	0,53
<b>U28</b>	0,44	0,5	0,56	0,4	0,46	0,51	0,38	0,44	0,5	0,37	0,42	0,48	0,36	0,41	0,47
<b>U30</b>	0,47	0,53	0,59	0,43	0,49	0,55	0,41	0,47	0,53	0,4	0,46	0,52	0,39	0,45	0,51
<b>U32</b>	0,45	0,51	0,57	0,41	0,47	0,53	0,4	0,45	0,51	0,38	0,44	0,5	0,38	0,43	0,49
<b>U38</b>	0,46	0,52	0,57	0,42	0,48	0,54	0,4	0,46	0,52	0,39	0,45	0,51	0,39	0,45	0,51
<b>U45</b>	0,37	0,43	0,49	0,34	0,39	0,45	0,32	0,37	0,43	0,31	0,36	0,42	0,3	0,36	0,41
<b>U50</b>	0,35	0,4	0,46	0,31	0,37	0,42	0,3	0,35	0,4	0,29	0,34	0,39	0,28	0,33	0,39
<b>U55</b>	0,4	0,46	0,52	0,37	0,43	0,48	0,36	0,41	0,47	0,35	0,41	0,46	0,35	0,41	0,46
<b>U60</b>	0,31	0,36	0,42	0,28	0,32	0,38	0,26	0,31	0,36	0,25	0,3	0,35	0,25	0,29	0,34
<b>U70</b>	0,34	0,39	0,45	0,31	0,36	0,41	0,29	0,34	0,4	0,29	0,34	0,39	0,29	0,34	0,39
<b>U75</b>	0,26	0,31	0,36	0,23	0,28	0,33	0,22	0,26	0,31	0,21	0,25	0,3	0,21	0,25	0,3
<b>U90</b>	0,23	0,27	0,32	0,2	0,24	0,29	0,19	0,23	0,27	0,18	0,22	0,26	0,18	0,22	0,26
<b>U100</b>	0,28	0,33	0,38	0,25	0,3	0,35	0,24	0,29	0,34	0,24	0,28	0,33	0,24	0,28	0,33

The stated values are approximate values

\* module m = 0,75

\*\* module m = 1,15

## Operative efficiency

Efficiency factors depending on input (worm) speed and lubrication (mineral grease 'MG', mineral oil 'MO' or synthetic grease, synthetic oil 'SO')

### A33

	n <sub>1</sub> = 2800 rpm			n <sub>1</sub> = 1400 rpm			n <sub>1</sub> = 950 rpm			n <sub>1</sub> = 700 rpm			n <sub>1</sub> = 500 rpm		
	MG	MO	SO	MG	MO	SO	MG	MO	SO	MG	MO	SO	MG	MO	SO
U3,5	0,79	0,83	0,86	0,77	0,81	0,84	0,75	0,79	0,83	0,74	0,78	0,82	0,72	0,77	0,81
U5	0,77	0,81	0,84	0,74	0,78	0,82	0,72	0,76	0,81	0,71	0,75	0,8	0,69	0,74	0,79
U7	0,72	0,77	0,81	0,69	0,74	0,78	0,67	0,72	0,77	0,66	0,71	0,76	0,65	0,7	0,75
U10	0,69	0,74	0,78	0,65	0,7	0,75	0,64	0,69	0,74	0,62	0,68	0,73	0,61	0,67	0,72
U11	0,65	0,7	0,75	0,61	0,67	0,72	0,6	0,65	0,7	0,58	0,64	0,69	0,57	0,63	0,68
U12	0,66	0,71	0,75	0,62	0,67	0,72	0,6	0,66	0,71	0,59	0,64	0,7	0,58	0,63	0,69
U14	0,57	0,63	0,68	0,53	0,59	0,65	0,51	0,57	0,63	0,5	0,56	0,62	0,49	0,54	0,6
U15	0,6	0,65	0,7	0,56	0,62	0,67	0,54	0,6	0,65	0,53	0,58	0,64	0,51	0,57	0,63
U16	0,63	0,68	0,73	0,59	0,64	0,7	0,57	0,63	0,68	0,56	0,62	0,67	0,55	0,61	0,66
U17	0,61	0,66	0,71	0,57	0,62	0,68	0,55	0,61	0,66	0,54	0,6	0,65	0,53	0,59	0,64
U18	0,55	0,61	0,67	0,51	0,57	0,63	0,5	0,55	0,61	0,48	0,54	0,6	0,47	0,53	0,59
U20	0,54	0,6	0,66	0,5	0,56	0,62	0,49	0,54	0,6	0,47	0,53	0,59	0,46	0,52	0,58
U24	0,49	0,55	0,61	0,45	0,51	0,57	0,44	0,5	0,55	0,42	0,48	0,54	0,41	0,47	0,53
U28	0,4	0,46	0,52	0,37	0,42	0,48	0,35	0,4	0,46	0,33	0,39	0,45	0,32	0,38	0,43
U30	0,43	0,49	0,55	0,39	0,45	0,51	0,37	0,43	0,49	0,36	0,42	0,47	0,35	0,4	0,46
U32	0,46	0,52	0,58	0,42	0,48	0,54	0,4	0,46	0,52	0,39	0,45	0,51	0,38	0,44	0,5
U38	0,41	0,47	0,53	0,37	0,43	0,49	0,36	0,41	0,47	0,34	0,4	0,46	0,33	0,39	0,45
U50	0,31	0,36	0,42	0,28	0,33	0,38	0,26	0,31	0,38	0,25	0,3	0,35	0,24	0,29	0,34
U56	0,29	0,34	0,39	0,25	0,3	0,35	0,24	0,29	0,34	0,23	0,27	0,32	0,22	0,26	0,31
U60	0,31	0,36	0,42	0,28	0,33	0,38	0,26	0,31	0,37	0,25	0,3	0,35	0,25	0,29	0,35
U72	0,22	0,26	0,31	0,19	0,23	0,28	0,18	0,22	0,26	0,17	0,21	0,25	0,17	0,2	0,24
U75	0,24	0,28	0,33	0,21	0,25	0,29	0,2	0,24	0,28	0,19	0,23	0,27	0,18	0,22	0,26

### A35

	n <sub>1</sub> = 2800 rpm			n <sub>1</sub> = 1400 rpm			n <sub>1</sub> = 950 rpm			n <sub>1</sub> = 700 rpm			n <sub>1</sub> = 500 rpm		
	MG	MO	SO	MG	MO	SO	MG	MO	SO	MG	MO	SO	MG	MO	SO
U2,78	0,81	0,85	0,87	0,79	0,83	0,86	0,77	0,81	0,84	0,76	0,8	0,84	0,75	0,79	0,83
U5	0,78	0,82	0,85	0,75	0,79	0,83	0,73	0,78	0,82	0,72	0,77	0,81	0,71	0,76	0,8
U7,25	0,71	0,75	0,8	0,68	0,73	0,77	0,65	0,71	0,75	0,64	0,69	0,74	0,63	0,68	0,73
U8	0,71	0,76	0,8	0,68	0,73	0,77	0,66	0,71	0,76	0,65	0,7	0,75	0,63	0,69	0,74
U10	0,66	0,71	0,76	0,62	0,68	0,73	0,6	0,66	0,71	0,59	0,64	0,7	0,57	0,63	0,68
U11	0,65	0,7	0,75	0,62	0,67	0,72	0,6	0,65	0,7	0,58	0,64	0,69	0,57	0,63	0,68
U12	0,63	0,68	0,73	0,59	0,64	0,7	0,57	0,62	0,68	0,55	0,61	0,66	0,54	0,6	0,65
U15	0,57	0,62	0,68	0,53	0,59	0,64	0,5	0,56	0,62	0,49	0,55	0,61	0,48	0,54	0,59
U20	0,51	0,57	0,62	0,47	0,53	0,59	0,45	0,51	0,56	0,43	0,49	0,55	0,42	0,48	0,54
U25	0,44	0,5	0,56	0,4	0,46	0,52	0,38	0,44	0,5	0,37	0,42	0,48	0,35	0,41	0,47
U30	0,4	0,45	0,51	0,36	0,42	0,47	0,34	0,39	0,45	0,33	0,38	0,44	0,31	0,37	0,42
U35	0,41	0,47	0,53	0,37	0,43	0,49	0,36	0,41	0,47	0,34	0,4	0,46	0,33	0,39	0,44
U40	0,34	0,4	0,45	0,31	0,36	0,42	0,29	0,34	0,4	0,28	0,33	0,38	0,27	0,32	0,37
U50	0,28	0,33	0,39	0,25	0,3	0,35	0,24	0,28	0,33	0,23	0,27	0,32	0,22	0,26	0,31
U58	0,3	0,35	0,41	0,27	0,32	0,37	0,26	0,3	0,35	0,24	0,29	0,34	0,24	0,28	0,33
U90	0,18	0,22	0,26	0,16	0,19	0,23	0,15	0,18	0,22	0,14	0,17	0,21	0,13	0,16	0,2

The stated values are approximate values

### Operative efficiency

Efficiency factors depending on input (worm) speed and lubrication (mineral grease 'MG', mineral oil 'MO' or synthetic grease, synthetic oil 'SO')

#### A40

	n <sub>1</sub> = 2800 rpm			n <sub>1</sub> = 1400 rpm			n <sub>1</sub> = 950 rpm			n <sub>1</sub> = 700 rpm			n <sub>1</sub> = 500 rpm		
	MG	MO	SO	MG	MO	SO	MG	MO	SO	MG	MO	SO	MG	MO	SO
<b>U6,75</b>	0,77	0,81	0,84	0,74	0,78	0,82	0,72	0,77	0,81	0,71	0,76	0,8	0,7	0,75	0,79
<b>U8</b>	0,74	0,78	0,82	0,7	0,75	0,79	0,68	0,73	0,78	0,67	0,72	0,77	0,66	0,71	0,76
<b>U10</b>	0,72	0,77	0,81	0,69	0,74	0,78	0,67	0,72	0,77	0,66	0,71	0,76	0,65	0,7	0,75
<b>U12</b>	0,65	0,7	0,75	0,62	0,67	0,72	0,6	0,65	0,7	0,58	0,64	0,69	0,57	0,62	0,68
<b>U15</b>	0,64	0,69	0,74	0,6	0,65	0,71	0,58	0,64	0,69	0,57	0,62	0,68	0,55	0,61	0,66
<b>U20</b>	0,61	0,66	0,71	0,57	0,63	0,68	0,55	0,61	0,66	0,54	0,6	0,65	0,53	0,59	0,64
<b>U25</b>	0,52	0,58	0,64	0,48	0,54	0,6	0,46	0,52	0,58	0,45	0,51	0,56	0,43	0,49	0,55
<b>U28</b>	0,47	0,53	0,59	0,43	0,49	0,55	0,41	0,47	0,53	0,4	0,46	0,52	0,39	0,44	0,5
<b>U30</b>	0,51	0,57	0,62	0,47	0,53	0,59	0,45	0,51	0,57	0,44	0,5	0,55	0,43	0,48	0,54
<b>U35</b>	0,49	0,55	0,6	0,45	0,51	0,57	0,43	0,49	0,55	0,42	0,48	0,54	0,41	0,47	0,53
<b>U36</b>	0,39	0,45	0,5	0,35	0,41	0,47	0,33	0,39	0,44	0,32	0,37	0,43	0,31	0,36	0,42
<b>U38</b>	0,41	0,47	0,53	0,37	0,43	0,49	0,36	0,41	0,47	0,34	0,4	0,45	0,33	0,38	0,44
<b>U40</b>	0,44	0,5	0,56	0,4	0,46	0,52	0,38	0,44	0,5	0,37	0,43	0,48	0,36	0,41	0,47
<b>U50</b>	0,42	0,48	0,54	0,38	0,44	0,5	0,37	0,42	0,48	0,35	0,41	0,47	0,35	0,4	0,46
<b>U56</b>	0,31	0,36	0,42	0,28	0,33	0,38	0,26	0,31	0,36	0,25	0,3	0,35	0,24	0,29	0,34
<b>U60</b>	0,28	0,33	0,38	0,25	0,29	0,34	0,23	0,28	0,32	0,22	0,26	0,31	0,21	0,25	0,3
<b>U70</b>	0,35	0,4	0,46	0,31	0,37	0,42	0,3	0,35	0,4	0,29	0,34	0,39	0,28	0,33	0,39
<b>U75</b>	0,25	0,3	0,35	0,23	0,27	0,32	0,21	0,25	0,3	0,2	0,24	0,29	0,19	0,23	0,28
<b>U80</b>	0,28	0,33	0,39	0,25	0,3	0,35	0,24	0,28	0,33	0,23	0,27	0,32	0,22	0,26	0,31
<b>U90</b>	0,29	0,34	0,4	0,36	0,31	0,36	0,25	0,29	0,35	0,24	0,28	0,33	0,23	0,28	0,33

#### A50

	n <sub>1</sub> = 2800 rpm			n <sub>1</sub> = 1400 rpm			n <sub>1</sub> = 950 rpm			n <sub>1</sub> = 700 rpm			n <sub>1</sub> = 500 rpm		
	MG	MO	SO	MG	MO	SO	MG	MO	SO	MG	MO	SO	MG	MO	SO
<b>U4,25</b>	0,8	0,84	0,87	0,78	0,82	0,85	0,76	0,8	0,84	0,75	0,79	0,83	0,74	0,78	0,82
<b>U6</b>	0,77	0,81	0,84	0,74	0,78	0,82	0,72	0,77	0,81	0,71	0,76	0,8	0,7	0,74	0,79
<b>U8</b>	0,72	0,76	0,8	0,69	0,74	0,78	0,67	0,72	0,76	0,65	0,7	0,75	0,64	0,69	0,74
<b>U12</b>	0,66	0,71	0,76	0,63	0,68	0,73	0,61	0,66	0,71	0,59	0,65	0,7	0,58	0,63	0,69
<b>U13,5</b>	0,65	0,7	0,74	0,61	0,67	0,72	0,59	0,64	0,7	0,57	0,63	0,68	0,56	0,62	0,67
<b>U19</b>	0,55	0,61	0,66	0,52	0,57	0,63	0,49	0,55	0,61	0,48	0,54	0,59	0,46	0,52	0,58
<b>U23</b>	0,52	0,58	0,64	0,49	0,55	0,6	0,46	0,52	0,58	0,45	0,51	0,57	0,43	0,49	0,55
<b>U27</b>	0,48	0,54	0,59	0,44	0,5	0,56	0,42	0,48	0,54	0,4	0,46	0,52	0,39	0,45	0,51
<b>U35</b>	0,43	0,49	0,55	0,4	0,45	0,51	0,37	0,43	0,49	0,36	0,41	0,47	0,34	0,4	0,46
<b>U46</b>	0,36	0,41	0,47	0,32	0,38	0,43	0,3	0,36	0,41	0,29	0,34	0,4	0,28	0,33	0,38
<b>U55</b>	0,31	0,37	0,42	0,29	0,34	0,39	0,27	0,31	0,37	0,25	0,3	0,35	0,24	0,29	0,34
<b>U69</b>	0,27	0,32	0,37	0,24	0,29	0,34	0,23	0,27	0,32	0,21	0,26	0,3	0,2	0,25	0,29

The stated values are approximate values

## Operative efficiency

Efficiency factors depending on input (worm) speed and lubrication (mineral grease 'MG', mineral oil 'MO' or synthetic grease, synthetic oil 'SO')

### A53

	n <sub>1</sub> = 2800 rpm			n <sub>1</sub> = 1400 rpm			n <sub>1</sub> = 950 rpm			n <sub>1</sub> = 700 rpm			n <sub>1</sub> = 500 rpm		
	MG	MO	SO	MG	MO	SO	MG	MO	SO	MG	MO	SO	MG	MO	SO
<b>U4,75</b>	0,8	0,84	0,87	0,78	0,82	0,85	0,76	0,8	0,84	0,75	0,79	0,83	0,74	0,78	0,82
<b>U6,67</b>	0,77	0,81	0,84	0,74	0,78	0,82	0,72	0,77	0,81	0,71	0,76	0,8	0,7	0,74	0,79
<b>U9,67</b>	0,72	0,76	0,8	0,69	0,74	0,78	0,67	0,72	0,76	0,65	0,7	0,75	0,64	0,69	<b>0,74</b>
<b>U13,5</b>	0,66	0,71	0,76	0,63	0,68	0,73	0,61	0,66	0,71	0,59	0,65	0,7	0,58	0,63	0,69
<b>U15</b>	0,65	0,7	0,74	0,61	0,67	0,72	0,59	0,64	0,7	0,57	0,63	0,68	0,56	0,62	0,67
<b>U21</b>	0,55	0,61	0,66	0,52	0,57	0,63	0,49	0,55	0,61	0,48	0,54	0,59	0,46	0,52	0,58
<b>U25</b>	0,52	0,58	0,64	0,49	0,55	0,6	0,46	0,52	0,58	0,45	0,51	0,57	0,43	0,49	0,55
<b>U28</b>	0,44	0,5	0,56	0,41	0,47	0,53	0,39	0,45	0,51	0,37	0,43	0,49	0,36	0,42	0,47
<b>U30</b>	0,48	0,54	0,59	0,44	0,5	0,56	0,42	0,48	0,54	0,4	0,46	0,52	0,39	0,45	0,51
<b>U38</b>	0,43	0,49	0,55	0,4	0,45	0,51	0,37	0,43	0,49	0,36	0,41	0,47	0,34	0,4	0,46
<b>U50</b>	0,36	0,41	0,47	0,32	0,38	0,43	0,3	0,36	0,41	0,29	0,34	0,4	0,28	0,33	0,38
<b>U60</b>	0,31	0,37	0,42	0,29	0,34	0,39	0,27	0,31	0,37	0,25	0,3	0,35	0,24	0,29	0,34
<b>U75</b>	0,27	0,32	0,37	0,24	0,29	0,34	0,23	0,27	0,32	0,21	0,26	0,3	0,2	0,25	0,29

### A63

	n <sub>1</sub> = 2800 rpm			n <sub>1</sub> = 1400 rpm			n <sub>1</sub> = 950 rpm			n <sub>1</sub> = 700 rpm			n <sub>1</sub> = 500 rpm		
	MG	MO	SO	MG	MO	SO	MG	MO	SO	MG	MO	SO	MG	MO	SO
<b>U6</b>	0,8	0,84	0,87	0,78	0,82	0,85	0,76	0,8	0,84	0,75	0,79	0,83	0,74	0,78	0,82
<b>U12</b>	0,72	0,76	0,8	0,69	0,74	0,78	0,67	0,72	0,76	0,65	0,7	0,75	0,64	0,69	0,74
<b>U19</b>	0,65	0,71	0,75	0,62	0,67	0,72	0,6	0,65	0,7	0,58	0,64	0,69	0,57	0,62	0,68
<b>U26</b>	0,55	0,61	0,66	0,52	0,57	0,63	0,49	0,55	0,61	0,48	0,54	0,59	0,46	0,52	0,58
<b>U34</b>	0,5	0,56	0,62	0,47	0,53	0,58	0,44	0,5	0,56	0,43	0,49	0,54	0,41	0,47	0,53
<b>U48</b>	0,43	0,49	0,55	0,4	0,45	0,51	0,37	0,43	0,49	0,36	0,41	0,47	0,34	0,4	0,46
<b>U63</b>	0,36	0,41	0,47	0,32	0,38	0,43	0,3	0,36	0,41	0,29	0,34	0,4	0,28	0,33	0,38
<b>U70</b>	0,29	0,34	0,39	0,26	0,31	0,36	0,24	0,29	0,34	0,23	0,28	0,32	0,22	0,26	0,3

The stated values are approximate values

### Operative efficiency

Efficiency factors depending on input (worm) speed and lubrication (mineral grease 'MG', mineral oil 'MO' or synthetic grease, synthetic oil 'SO')

#### A65

	n <sub>1</sub> = 2800 rpm			n <sub>1</sub> = 1400 rpm			n <sub>1</sub> = 950 rpm			n <sub>1</sub> = 700 rpm			n <sub>1</sub> = 500 rpm		
	MG	MO	SO	MG	MO	SO	MG	MO	SO	MG	MO	SO	MG	MO	SO
<b>U6,25</b>	0,8	0,84	0,87	0,78	0,82	0,85	0,76	0,8	0,84	0,75	0,79	0,83	0,74	0,78	0,82
<b>U12,66</b>	0,72	0,76	0,8	0,69	0,74	0,78	0,67	0,72	0,76	0,65	0,7	0,75	0,64	0,69	0,74
<b>U20</b>	0,65	0,71	0,75	0,62	0,67	0,72	0,6	0,65	0,7	0,58	0,64	0,69	0,57	0,62	0,68
<b>U28</b>	0,55	0,61	0,66	0,52	0,57	0,63	0,49	0,55	0,61	0,48	0,54	0,59	0,46	0,52	0,58
<b>U36</b>	0,5	0,56	0,62	0,47	0,53	0,58	0,44	0,5	0,56	0,43	0,49	0,54	0,41	0,47	0,53
<b>U50</b>	0,43	0,49	0,55	0,4	0,45	0,51	0,37	0,43	0,49	0,36	0,41	0,47	0,34	0,4	0,46
<b>U66</b>	0,36	0,41	0,47	0,32	0,38	0,43	0,3	0,36	0,41	0,29	0,34	0,4	0,28	0,33	0,38
<b>U75</b>	0,29	0,34	0,39	0,26	0,31	0,36	0,24	0,29	0,34	0,23	0,28	0,32	0,22	0,26	0,31

#### A80

	n <sub>1</sub> = 2800 rpm			n <sub>1</sub> = 1400 rpm			n <sub>1</sub> = 950 rpm			n <sub>1</sub> = 700 rpm			n <sub>1</sub> = 500 rpm		
	MG	MO	SO	MG	MO	SO	MG	MO	SO	MG	MO	SO	MG	MO	SO
<b>U6,75</b>	0,79	0,83	0,86	0,78	0,82	0,85	0,76	0,8	0,84	0,75	0,79	0,83	0,73	0,78	0,82
<b>U12</b>	0,75	0,79	0,83	0,72	0,77	0,81	0,7	0,75	0,79	0,69	0,74	0,78	0,68	0,73	0,77
<b>U20</b>	0,63	0,69	0,74	0,61	0,66	0,71	0,59	0,64	0,7	0,57	0,63	0,68	0,55	0,61	0,67
<b>U30</b>	0,53	0,59	0,64	0,51	0,57	0,62	0,49	0,55	0,6	0,47	0,53	0,58	0,45	0,51	0,57
<b>U50</b>	0,45	0,51	0,57	0,42	0,48	0,53	0,4	0,45	0,51	0,38	0,44	0,49	0,37	0,42	0,48
<b>U80</b>	0,3	0,35	0,41	0,28	0,33	0,38	0,27	0,31	0,37	0,25	0,3	0,35	0,24	0,28	0,33

The stated values are approximate values

## Tolerance

### Backlash tolerances for worm gears (valid for gears with a pressure angle of 15°)

$\beta_0$  corresponds to  $m$  of the worm

Pitch diameter of the worm gear	Module $m_n$	Backlash tol. at pitch diameter [mm]			
		$\beta_0$ up to 24°		$\beta_0$ over 24°	
		min.	max.	min.	max.
over 12 up to 25	0,4 - 0,6	0,07	0,092	0,077	0,102
	>0,6 - 1,3	0,075	0,099	0,083	0,109
	>1,3 - 2,0	0,08	0,106	0,089	0,117
over 25 up to 50	0,4 - 0,6	0,075	0,099	0,083	0,108
	>0,6 - 1,3	0,08	0,106	0,089	0,117
	>1,3 - 2,0	0,086	0,114	0,095	0,125
	>2,0 - 4,0	0,094	0,124	0,103	0,137
over 50 up to 100	0,4 - 0,6	0,08	0,106	0,089	0,117
	>0,6 - 1,3	0,086	0,114	0,095	0,125
	>1,3 - 2,0	0,094	0,124	0,103	0,137
	>2,0 - 4,0	0,102	0,134	0,112	0,148

The backlash values are based on an ideal center distance. More backlash will appear if the center distance is actually at the upper tolerance. 0.05mm above ideal center distance will result in 0.027 mm more backlash.

## Lubrication

Lubrication has an essential influence on efficiency, heat generation and life time. A good choice is a synthetic oil on the basis of polyglykol and synthetic oil or grease on the basis of polyalphaolefin. Moreover polyalphaolefin has a high compatibility to common sealing materials.

High viscosity synthetic oils (ISO VG 680 bzw. ISO VG 1000) are used preferably for worm gear sets. In case of smaller center distances mineral or synthetic grease in consistency-class 0 up to 00 can be used as well.

## Comparison of the different basis oils

Characteristics	Mineral oil	Polyalphaolefin synth.	Polyglykol synth.
Viscosity at low temp.	4	3	3
Wear protection	4	2	1
Frictional behaviour	3	2	1
High temp. Oxidation stability	4	2	1
Water separation ability	4	2	5
Air release ability	3	2	4
Rust protection	1	1	3
Mix with mineral oil	-	1	5
Laquer compatibility	1	1	3
Seal compatibility	1	1	3
Low evaporation losses	4	1	3

1=excellent

2=very good

3=good

4=sufficient

5=bad

## Contact

### Framo Morat GmbH & Co. KG

Franz-Morat-Straße 6  
 79871 Eisenbach  
 Germany  
 Tel. +49 (0) 7657 / 88-0  
 Fax +49 (0) 7657 / 88-222  
 e-mail: [info@framo-morat.com](mailto:info@framo-morat.com)  
[www.framo-morat.com](http://www.framo-morat.com)

### Heinrich Wolf GmbH & Co. KG

Antriebs- und Steuerungstechnik  
 Röntgenstrasse 1  
 23701 Eutin  
 Germany  
 Mr. Carsten Röben  
 Tel. +49 (0)4521 / 739 52  
 Fax: +49 (0)4521 / 742 79  
[info@wolf-eutin.de](mailto:info@wolf-eutin.de)  
[www.wolf-eutin.de](http://www.wolf-eutin.de)

### Ronald Schöner Ingenieurbüro

Thomas-Mann-Str. 54  
 01219 Dresden  
 Germany  
 Mr. Ronald Schöner  
 Tel. +49 (0)351 4707 778  
 Fax: +49 (0)351 4707 372  
[schoener@ib-schoener.de](mailto:schoener@ib-schoener.de)

### Framo Morat Inc.

9440-L San Mateo Blvd NE  
 USA - Albuquerque, NM 87113  
 USA  
 Tel. +1 505 881 2177  
 Fax: +1 505 881 2070  
[usa@framo-morat.com](mailto:usa@framo-morat.com)  
[www.framo-morat.com](http://www.framo-morat.com)

### Framo Morat B.V

Westbaan 228  
 2841MC Moordrecht (NL)  
 Netherlands, Belgium, Luxembourg  
 Tel.: +31 (0) 182 / 610 006  
 Fax: +31 (0) 182 / 610 631  
 e-mail: [info@framo-morat.nl](mailto:info@framo-morat.nl)  
[www.framo-morat.nl](http://www.framo-morat.nl)

### Framo Morat Hareketli Sistemler

**San. ve Tic. Ltd. Şti.**  
 Çobançeşme Mah. Sanayi Cad. No:44/C  
 Nish İstanbul Residence  
 K:6/70 B.Evler / İSTANBUL  
 Turkey  
 Mr. Cem Ünlü  
 Tel. / Fax +90 212 9453845  
 Mobile: +90 532 5141031  
[cem@framo-morat.com](mailto:cem@framo-morat.com)  
[www.framo-morat.com.tr](http://www.framo-morat.com.tr)

### Fritz Kübler Sarl

Compteurs et Codeurs Industriels  
 2 rue de Grande Bretagne  
 68310 Wittelsheim  
 France  
 Mr. Guillaume Ducret  
 Tel. +33 38953 4545  
 Fax: +33 38953 6677  
[guillaume.ducret@kuebler-sarl.com](mailto:guillaume.ducret@kuebler-sarl.com)  
[www.kuebler.com](http://www.kuebler.com)

### R.A. Rodriguez (U.K.) Ltd.

28 Campus Five,  
 Letchworth Business Park  
 Letchworth Garden City  
 Herts. SG6 2JF  
 United Kingdom  
 Mr. Paul French  
 Tel. +44 1462 670 044  
 Fax: +44 1462 670 880  
[info@raruk.com](mailto:info@raruk.com)  
[www.raruk.com](http://www.raruk.com)

### EIE Maskin AB

Box 7  
 Skebokvarnsvägen 370  
 12421 Bandhagen  
 Sweden  
 Mr. Mattias Frick  
 Tel. +46 8727 8800  
 Fax: +46 8727 8899  
[eie@eie.se](mailto:eie@eie.se)  
[www.eie.se](http://www.eie.se)

### EIE Maskin Oy

PL 80, Asematie 1  
 FIN-10601 Tammisaari  
 Finland  
 Mr. Markus Evers  
 Tel. +358 19 2239100  
 Fax: +358 19 2239199  
[info@eie.fi](mailto:info@eie.fi)  
[www.eie.fi](http://www.eie.fi)

### ELMEKO AS

Tvetenveien 164  
 N-0671 OSLO  
 Norwegen  
 Mr. Lars Saether  
 Tel. +47 6757 2270  
 Fax: +47 6757 2280  
[elmeko@elmeko.no](mailto:elmeko@elmeko.no)  
[www.elmeko.no](http://www.elmeko.no)

### ATTI S.R.L. Articoli Tecnici

Transmissioni Industriali  
 Via F.lli Cervi, 3  
 I-20063 Cernusco sul Naviglio (MI)  
 Tel. 0039-0292 10 69 54  
 Fax 0039-0292 10 72 61  
[info@atti.it](mailto:info@atti.it)  
[www.atti.it](http://www.atti.it)

### ALUPTECH

3 Floor, 451-6 Dokok-Dong  
 Kangnam-Gu  
 Seoul Lorea  
 Republic of Korea  
 Mr. Ju-Sam Jang  
 Tel. +82 2576 2938  
 Fax: +82 2576 2939  
[aluptech@hanmail.net](mailto:aluptech@hanmail.net)

### Z.U.K. Motion-Systems &

Components  
 5 Yaanush kortzak st.  
 43208 Raanana  
 Israel  
 Mr. David Zukerman  
 Tel. +972 549 559 22  
 Fax: +972 974 252 20  
[zuk@netvision.net.il](mailto:zuk@netvision.net.il)

Subject to technical changes