

# TSUNTIEN

ムラタ精密





內容僅供參考，實際情況依網站公告為準，或洽本公司查詢。

## 目錄 CONTENTS

公司介紹	01	Company Introduction
獲獎&認證	02	Certification and Reward
生產機能	05	Production Capacity
製程&檢測	05	Manufacture Procedure and Quality Control
研發由來	06	Development Origin of TSUNTIEN
滾柱減速機特色	07	Feature of Roller Reducer
滾柱減速機構成	09	Structure of roller reducer
滾柱減速機原理	10	Principle of roller reducer
滾柱減速機部品名稱	11	Component
產品介紹	13	Product Introduction
應用實例	15	Application
TTRA-E 系列	17	TTRA-E Series
TTRA-E 訂購說明	18	TTRA-E Ordering Instructions
TTRA-E 安裝方式選項	19	TTRA-E Motor mounting selections
TTRA-E 產品性能表	21	TTRA-E Technical Specification Table
TTRA-E 產品尺寸圖	23	TTRA-E Drawing & Dimension

TTRAD-E 系列	27	TTRAD-E Serie
TTRAD-E 訂購說明	28	TTRAD-E Ordering Instructions
TTRAD-E 安裝方式選項	29	TTRAD-E Motor mounting selections
TTRAD-E 產品性能表	31	TTRAD-E Technical Specification Table
TTRAD-E 產品尺寸圖	33	TTRAD-E Drawing & Dimension
TTRV-E 系列	37	TTRV-E Serie
TTRV-E 訂購說明	38	TTRV-E Ordering Instructions
TTRV-E 產品性能表	39	TTRV-E Technical Specification Table
TTRV-E 產品尺寸圖	41	TTRV-E Drawing & Dimension
TTRV-C 系列	45	TTRV-C Serie
TTRV-C 訂購說明	46	TTRV-C Ordering Instructions
TTRV-C 產品性能表	47	TTRV-C Technical Specification Table
TTRV-C 產品尺寸圖	49	TTRV-C Drawing & Dimension
TTRD-C 系列	53	TTRD-C Serie
TTRD-C 訂購說明	54	TTRD-C Ordering Instructions
TTRD-C 產品性能表	55	TTRD-C Technical Specification Table
TTRD-C 產品尺寸圖	57	TTRD-C Drawing & Dimension
TTRAC-E 系列	61	TTRAC-E Serie
TTRAC-E 訂購說明	62	TTRAC-E Ordering Instructions
TTRAC-E 產品性能表	63	TTRAC-E Technical Specification Table
TTRAC-E 產品尺寸圖	65	TTRAC-E Drawing & Dimension
TTGH 系列	68	TTGH Series
TTGH 訂購說明	69	TTGH Ordering Instructions
TTGH 部品名稱	70	TTGH Component
TTGH 產品尺寸圖	71	TTGH Drawing & Dimension
設計注意事項	74	Product selection Guide
選用注意事項	75	Design Considerations
潤滑	79	Lubrication
使用注意事項	82	Application Notice



## 公司介紹 ABOUT TSUNTIEN

- 1990年專於減速機的開發與製作。
- 1991年研發出新型活齒傳動機構並加入於減速機內，形成滾柱減速機，並將其導入需高扭力且低背隙需求的機械中。
- 1994年獲得德國紐倫堡世界發明展金獎。
- 1995年獲得台灣經濟部中小企業創新研究獎。
- 2011年我們帶著20年經驗的滾柱減速機技術，加入了高精密減速機行列。
- 2012年“村田精密有限公司”導入了變位機，刀塔以及精密機械手臂產業的市場，評價甚佳。
- In1990, TSUNTIEN focused on development and production of the high performance reducer.
- In1991, TSUNTIEN released the innovative movable teeth drive mechanism and incorporated to reducer practically, which is the prototype of Roladrive reducer. The Roladrive reducer was applied successfully to the machine required high torque and low backlash.
- In1994, was granted IENA94 eine Gold-Medaille Award (Nuremberg, Germany.)
- In1995, Small And Medium Enterprise Innovation Research Award (Taiwan)
- In 2011, TSUNTIEN entered the high precision reducer industry accompanied more than 20-years sophisticated experience of Roladrive reducer technique.
- In 2012, TSUNTIEN has sold successfully to the market of positioner, turret and precision automatic robotic industry and won the good reputation.



## 村田研發由來 DEVELOPMENT ORIGIN OF TSUNTIEN

因應現代自動化產業機械手臂的趨勢，TSUNTIEN由中大較重的減速機機身，研發進化至薄小型較輕的減速機機身，使機械手臂能更節省空間，也輕量化了機械手臂的機身重量，同時也減少了慣性過大的問題。然而TSUNTIEN也特別研發提供變位機以及刀塔完善的減速機，簡單而緊固的安裝，直結的輸出，精確的定位。

高扭矩高轉矩的TSUNTIEN 減速機TSUNTIEN HIGH TORQUE REDUCER 擁有多滾柱齒型咬合使動力傳遞精確，轉矩較大，機械損失較小。針齒構造使噪音比一般齒輪減速機來的低，出力也較高。

In order to satisfying the mainstream of automatic robotic industry, TSUNTIEN proceeded to develop the heavier and bigger reducers at the beginning, then gradually toward to more compact and lighter reducer for space-saving requirement of automatic robotic industry which could lighten the weight of body of robotic arm, and eliminate the phenomenon of high inertia ratio meantime.

TSUNTIEN also released specific reducers by simple installation, direct drive with precise position, especially be suitable to be applied to positioner, turret and ATC industries.

With all roller-gears contact simultaneous, the power of transmission and torque are more precise and efficient. As a result, the mechanism loss is lower. Unique roller-gear structure obtains higher output torque, makes lower noise than conventional reducer. The reducer provide near zero backlash, the ability to support heavy external loads and has significant advantage in terms of easy fuse and low cost for performance.

# 生產機能

## Production Capacity

村田精密機械有限公司備有1000坪廠房，持續增加的CNC車、銑床，三班人馬的組立生產線，以及兩班制的車、銑床機台人員，另備有大量的協力廠商，可隨時應對大量的訂單來確保品質及產品的交期。

TSUNTIEN precision co., LTD with more than 3000 square meter new factory · adding modern workshop facilities and process equipment · such as CNC machining center · milling machine · gear-shaping machine · gear-grinding machine with flexible shift work ; Overall the inspection equipment such as teeth-profile equipment · CMM · noise · vibration measuring machine and so on ; Cooperated with long-term and reliable outsourcing suppliers · could meet any unpredictable mass orders and also ensure the premium quality meantime.



# 製程&檢測

## Manufacture Procedure & Quality Control

所有進料的素材都是經過許多儀器檢測材質，確保材質正確無誤後才進入加工階段，加工完每個零件都是由三次元檢測儀100%檢測保證所有零件都在公差範圍，才會進入組裝線進行組裝，當每台滾柱減速機組裝完成時，將進入出貨檢測，出貨檢測包含噪音，溫度，震動，平面偏擺以及平面跳動等多項檢測，當所有檢測項目都在標準值內才會進行包裝出貨，保障產品的品質。

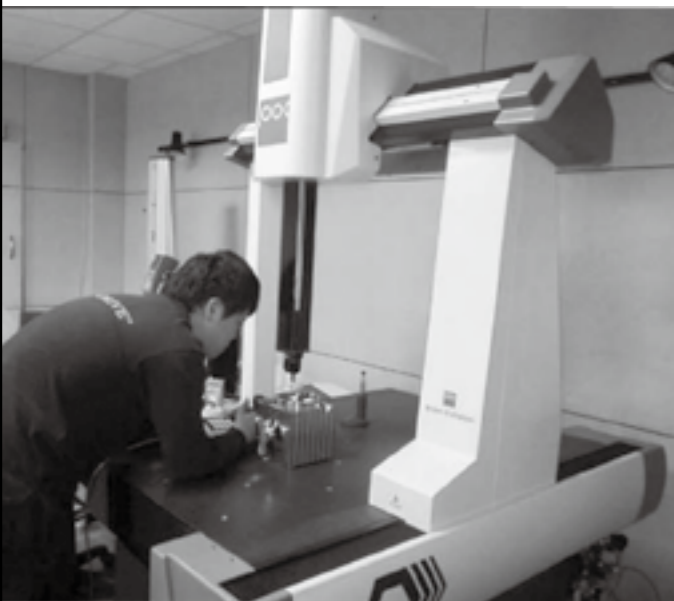

Pre--inspection: All raw materials are certified that ingredients are correct by suppliers and QC dept. before process procedures. Each part has to be measured strictly by gauge · caliper or CMM in order to ensuring the dimensions are with in tolerance range according to the corresponding drawing.

Finished inspection: Each assembled Roladrive reducer is necessary to be inspected these items · including noise · temperature · flatness runout · and flatness shake ...etc. All inspection items of each Roladrive reducer have to meet the strict regulation of TSUNTIEN to ensure the product quality before packing and shipment.

# 獲獎&認證

## Award & Certificate



1993年榮獲全國發明展金頭腦獎

1992年榮獲德國紐倫堡世界發明展金牌獎

經濟部中小企業創新研究獎

2011年通過 ISO9001 SGS 國際認證



# 滾柱減速機特色

## Feature Of Roller Reducer

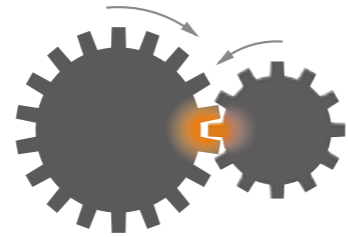
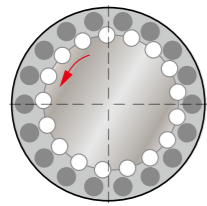
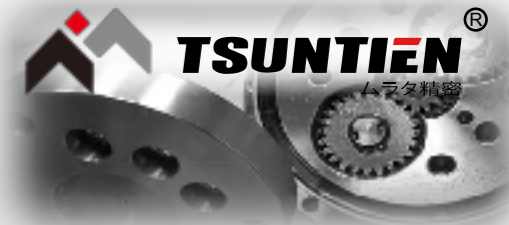

▲ 採用多齒嚙合承載的功率分散技術，能大幅提高衝擊負載的能力。

Load-decentralized technology via multi-gear engagement · enhance raise impact capability rapidly.

▲ 傳統的正齒輪或螺旋齒輪全部得過負載衝擊，只由一次一個齒分擔。

Conventional spur or helical gear must bear over-load impact due to merely one-tooth engagement in each mesh.

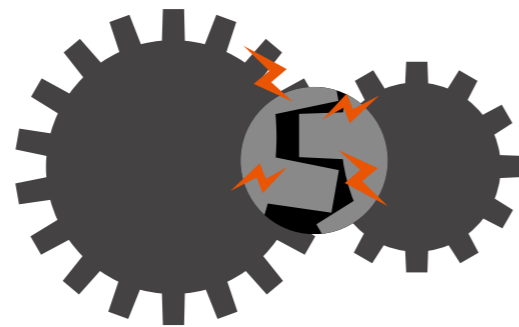
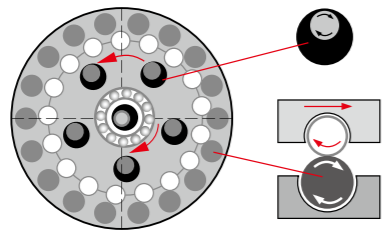

▲ 內外輪齒是以滑動中帶完全的滾動來接觸，傳動效率特別高。

Drive of external & internal rollers involved sliding and rotation-self · obtain extremely high efficiency.

▲ 傳統的齒輪傳動結構會因磨損或齒輪干涉而造成轉矩傳遞不順暢。

The unsmooth torque transmission caused by the abrasion or interference of gear in conventional mechanism.

### 傳動新穎、優點獨具 Innovative transmission · significant advantage

具有諧波齒輪傳動的優點而無柔輪，具有少齒差行星傳動大傳動比而無長度過長問題，具有波動傳動承載力大的優點而無波動傳動之震動。

The features and benefits: With advantages of Harmonic gear drive without the weakness of flexspline · With high ratio of planetary gear drive without the length concern With benefit of high loading capacity of wave drive without the vibration.

### 滑動微小、效率最高 Low sliding loss · high efficiency

由於嚙合件均係滾柱構成，全系統基本上為滑動中帶滾動，機械損失微乎其微，所以可得極高的齒輪傳動效率，單段減速機最高可達95%左右。

All sliding parts composed of rollers · whose operation involve sliding and rolling at the same time · therefore the mechanism loss is almost neglected and obtained extremely high efficiency. The efficiency up to 95% under one stage reduction.

### 運轉平穩、噪音較低 Smooth operation · low noise

多齒嚙合，重疊係數大，雙排結構機理平衡，滾動及側間餘隙可避免輪齒干涉，使得機械震動及噪聲限制在最小程度。

Multi-teeth mesh simultaneous · high overlap-coefficient · balanced double-end support design · rolling contact and siding gap could avoid the interference and minimize the noise and vibration effectively.

### 傳動精確，誤差較小 High precision · low backlash

由於多齒嚙合，輪齒誤差可相互補償，因此傳動誤差值僅為齒輪減速機的25%。

The backlash could be eliminated due to multi-teeth engagement · therefore the transmission deviation is merely 25% of the conventional gear reducer.

### 激波徑大，出力較高 Long diameter of wave exciter · high torque output

由於激波規律的特性，滾柱波動傳動的激波徑一般均較其他行星傳動機構大，因此容許傳達轉矩也較高。

Due to regular characteristic of exciting wave · the diameter of exciting wave of roller-transmission is bigger than other conventional disc or carrier · so the torque is higher accordingly.

### 傳動比大，結構緊湊 High ratio · compact structure

傳動比為滾柱盤滾柱的個數，所以單段傳動即可獲得很大的傳動比，出入力軸位於同一軸心線上，結構精簡緊湊，和同條件的齒輪減速機及蝸輪減速機相比，體積顯的輕盈。

The number of rollers on the roller disc is equal to ratio · single stage can obtain high ratio. Output and input shaft are on co-axis and mechanisms are robust and space-saving, so the dimension is more compact compared to the worm reducer and gear reducer · especially on the high ratio ones.

### 多齒嚙合，承載力大 Multi-teeth engagement · high loading capability

雙波結構同時嚙合齒數可達50%，一般齒輪傳動僅約1齒，因此承載力比相同條件的齒輪減速機和蝸輪減速機來的大。

Half rollers mesh simultaneously of internal and external roller mechanism · compared to only one tooth mesh of conventional reducer · whose loads capacity is higher than worm reducer and gear reducer.

### 滾柱齒型，壽命最長 Roller tooth · long service life

獨創活齒機構，工藝良好，加工簡易，成本較低，加以所具有的真圓齒型，內聚力強，不易崩齒，不僅保養容易，壽命也較長。

Innovative movable teeth drive design · excellent handcraft · easy to manufacture · low cost and unique roller-gear structure · make overall robust mechanism · easy to maintenance and with durable service life.

### 耗能較省，經濟性佳 Low energy consumption · better economic benefit

由於出力大，效率高，能量損耗小，工作負荷減輕，長期運轉，經濟效益顯著。

High torque output and high efficiency · low energy consumption · low operation load · better economical benefit.

### 中空滾柱，輸出簡單 Hollow design · direct output

C TYPE 採用中空軸方式，便於設計，管線可容易排列穿過減速機，連軸器及馬達連接板使得容易與馬達安裝。

C TYPE-hollow shaft type · design-friendly · allows to array the routing hydraulic tubes and electrical cables through the reducer. Coupling and motor flange provide easy motor mounting.

# 滾柱減速機構成

## Structure of roller reducer

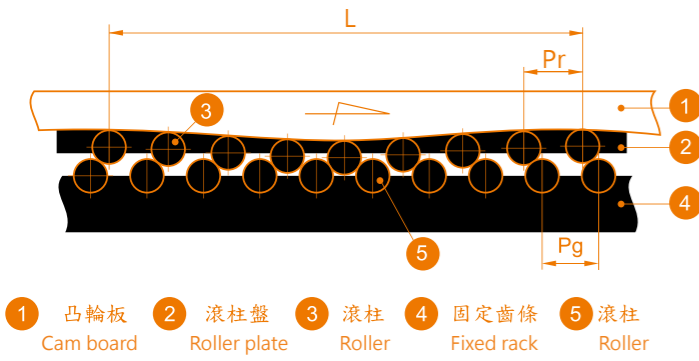

1 凸輪板 Cam board  
2 滾柱盤 Roller plate  
3 滾柱 Roller  
4 固定齒條 Fixed rack  
5 滾柱 Roller

### ▲展開 Stretch

將滾輪波動傳動展開如上圖所示，當凸輪板1單向移動將逐次壓下滾柱盤2內之滾柱3和固定齒條4之滾柱5嚙合，滾柱盤2上各滾柱3反向移動，滾柱3被拘限於滾柱盤2齒距Pr內，滾輪齒輪被推而連續移動。周而復始，不存在死點。而且滿足 $L = Tg \times Pg = Tr \times Pr$ 之關係。Tr和Tg為滾柱3和滾柱5之個數。

First, stretch the basic roller wave transmission as the figure 1, when crankshaft (1) moved to certain direction, propel roller (3) of roller disc (2) to mesh with roller (5) of roller rack (4), then rollers (3) of roller disc (2) are moved adversely, rollers (3) also are limited in the pitch (Pr) of roller disc (2), the rollers are propelled continuously, one by one, no dead point and meet below formula:  $L = Tg \times Pg = Tr \times Pr$ . Tr and Tg represent the number of roller(3) and roller(5) separately.

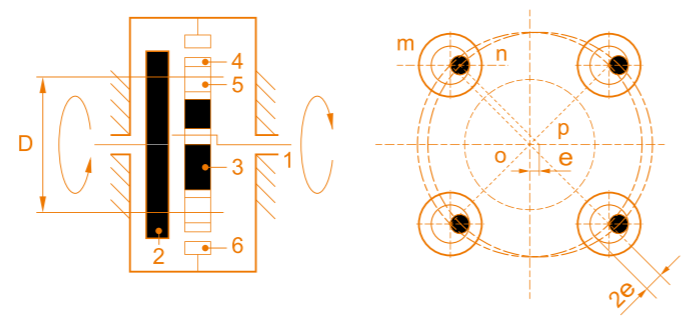

### ▲輸出 Output

將滾輪(齒輪3)受偏心圓1激動後，一面以高速公轉，一面以低速自轉，自轉減速可經由滾子4驅動滾子內之軸銷5(直接或間接固定於輸出軸2上)直接輸出。很容易證明mnop為平行四邊形，因此輸出轉速等於滾柱盤3之低速轉速。(如上圖所示)

The roller disc (3) are propelled by the eccentric cam (1), make the high speed revolution and the low speed rotation itself at the same time. Retarding rotation could propel shaft pin (5) via roller (4). (PS: shaft pin (5) mounted on output shaft (2) directly or indirectly), we can easily prove: the 4 points of m, n, o, p form a parallelogram, therefore output speed is equal to low speed of roller disc (3). Shown as the above figure.

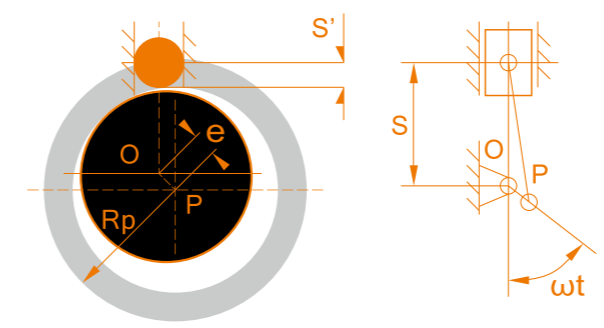

### ▲激波 Exciting wave

當固定齒條4的齒廓採用圓形滾柱5和激波器選用標準偏心圓時，其激波規律類似曲柄滑塊運動的規律(如上圖所示)。

$$S = R_p \cos \beta - e \cos \omega t$$

$$S' = \sqrt{R_p^2 - e^2 \sin^2 \omega t - e \cos \omega t - R_O}$$

- Rp = 偏心圓理論輪廓半徑
- Ro = 激波器基圓半徑
- β = 連杆和導軌中線間夾角
- e = 偏心距
- ω = 偏心圓角速
- t = 時間參數

The roller rack (4) adopting the profile of roller(5) and the wave exciter adopted standard eccentric cam, both interaction frequency is similar to motion of the crank-slide mechanism. Shown as the above figure.

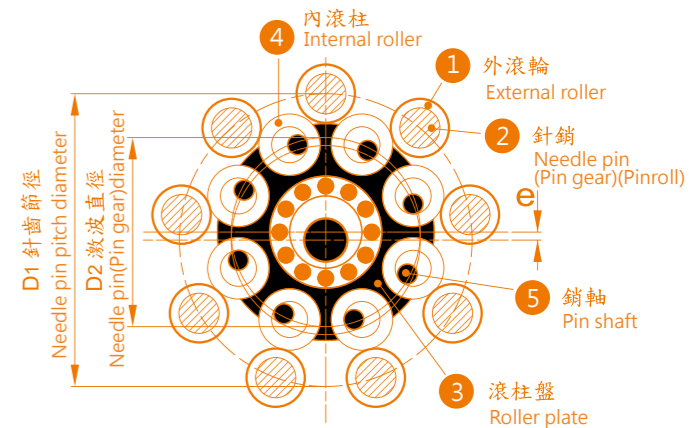

### ▲組合 Assembly

以上機構精巧組合如上圖所示，當滾柱盤3上之內滾柱4較小時，尤其在傳動比較大狀況下，滾柱內無法安置軸銷5時，通常將其置放於滾柱盤3上，其輸出轉速仍然不變，全系統基本上為純滾動接觸，機械損失非常微小，故可得極高之傳動效率。

The detail shown as the above figure, when inner rollers (4) of roller disc (3) are small so that shaft pin(5) can't be inserted into inner roller, especially high ratio status, shaft pin(5) is used to being put in roller disc (3) directly, also maintain the same output speed. Basically, this system is rolling contact completely with very low mechanical loss and obtain very high efficiency.

# 滾柱減速機原理

## Principle of roller reducer

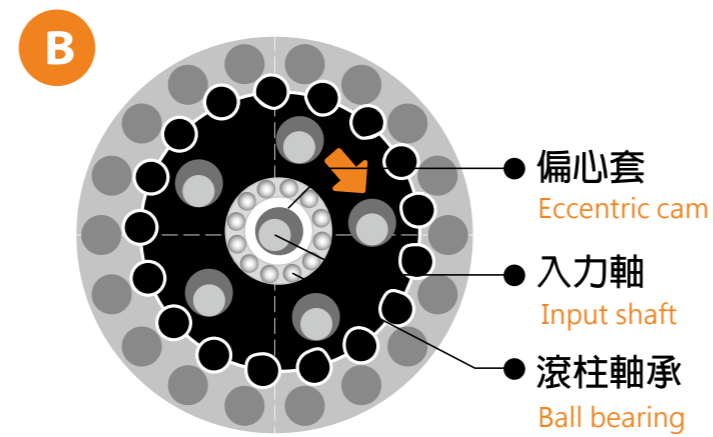
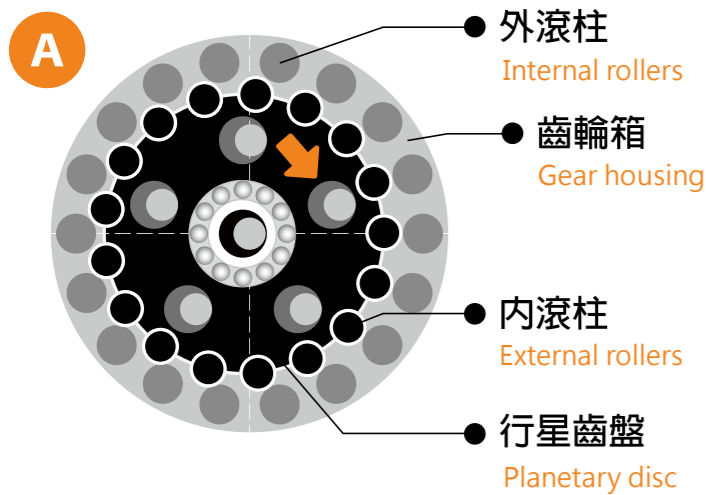
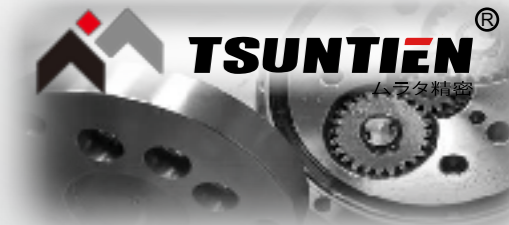

1. 圓柱型的外滾柱裝在強韌的齒輪箱上。
2. 圓柱型的內滾柱裝在精密的行星齒盤上。
3. 當入力軸以順時針方向回轉時，帶動偏心套也做順時針回轉。
4. 透過滾柱軸承，行星齒盤作反時針的偏心運轉。
5. 內滾柱將隨行星齒盤反時針的公轉。

1. Cylindrical external rollers mounted in robust housing.
2. Cylindrical internal rollers mounted in precision planetary disc.
3. Input shaft rotate clockwise to synchronously drive eccentric cam rotation clockwise.
4. Planetary disc turns counter-clockwise eccentrically propelled by the eccentric cam.
5. Internal rollers turn counter-clockwise accompanied with planetary disc.

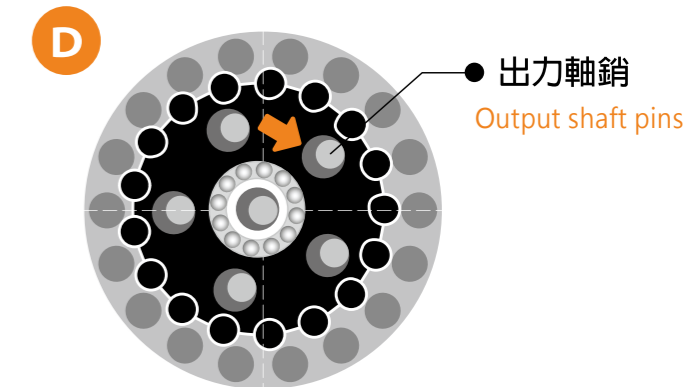
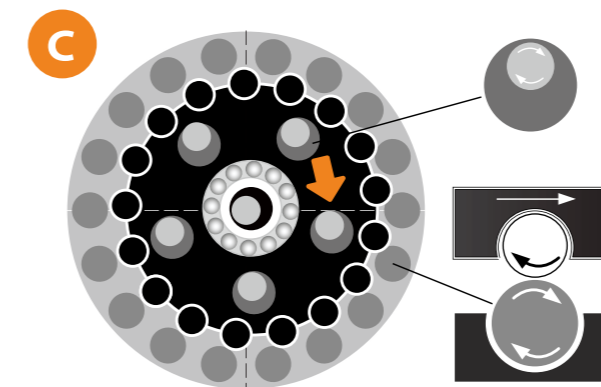

6. 在內滾柱將隨行星齒盤反時針的公轉的同時，因內外滾柱的嚙合傳遞，將使內外滾柱各繞其中心作順時針的自轉。
7. 由於內外滾柱均可繞其中心自由轉動，所以這種傳動方式我們稱之為完全活齒傳動。
8. 出力軸銷隨著行星齒盤的推移，將以反時針方向作公轉。與出力軸銷連結的出力軸也會做反時針方向的旋轉。
9. 如圖A至圖D所示，當入力軸迴轉一圈時，內滾柱將以反方向旋轉過一個齒。所以內滾柱的齒數也就等於減速比。

6. While internal rollers turning counter-clockwise accompanied with planetary disc, this make rotation of internal roller and external roller separately follow individual center axis due to mesh transmission.
7. Because the internal / external rollers can rotate freely around individual center, we called this transmission type "innovative movable teeth drive mechanism".
8. Output shaft pins propelled with planetary disc turn revolution counter-clockwise; output shaft connected with output shaft pins also turns counter-clockwise.
9. As figure A to D, input shaft turns for one cycle, internal rollers turn for one tooth in adverse direction. As a result, the number of teeth of internal rollers is equal to the reduction ratio.

# 滾柱減速機部品名稱

## Explosion drawing of roller reducer

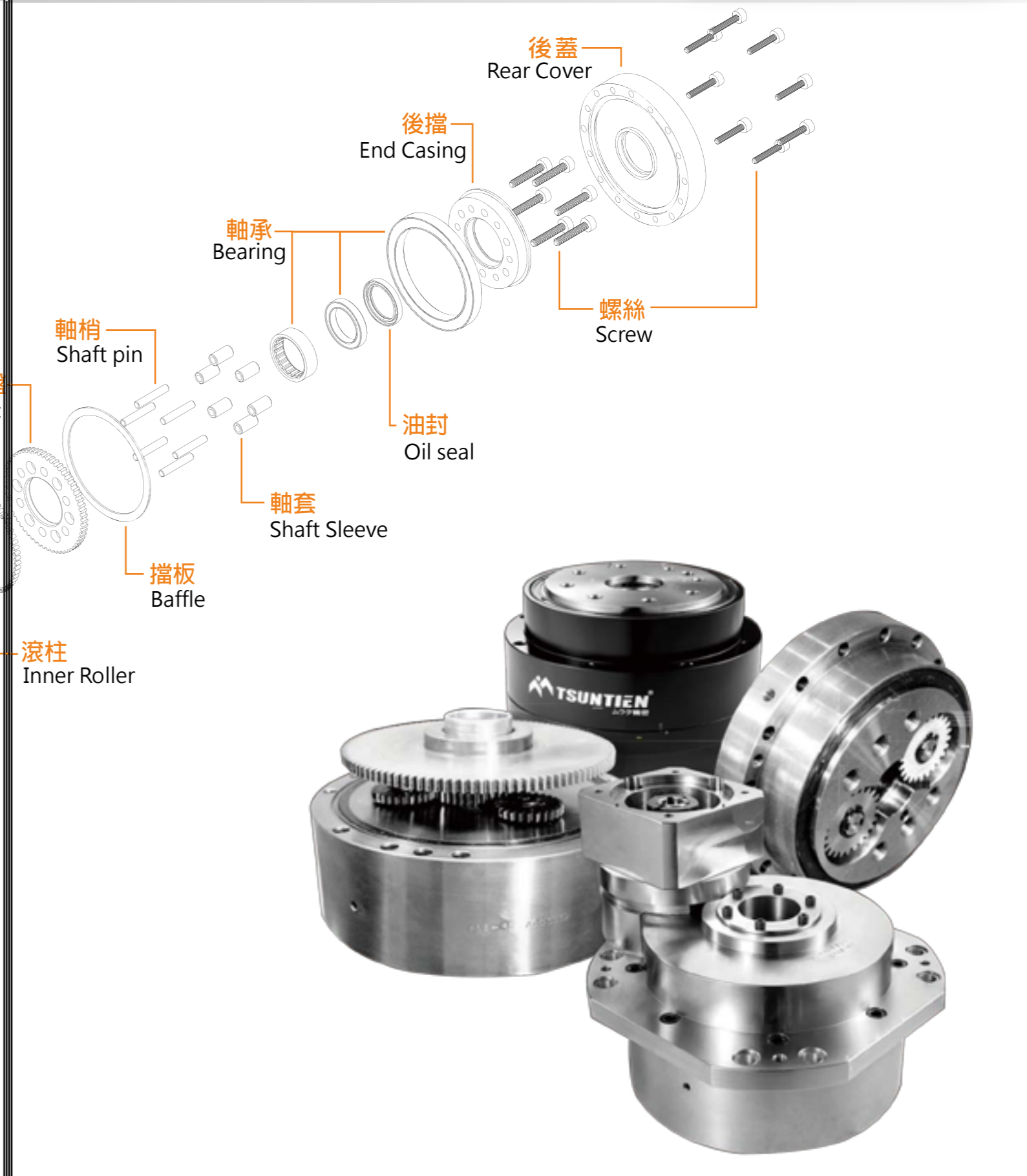
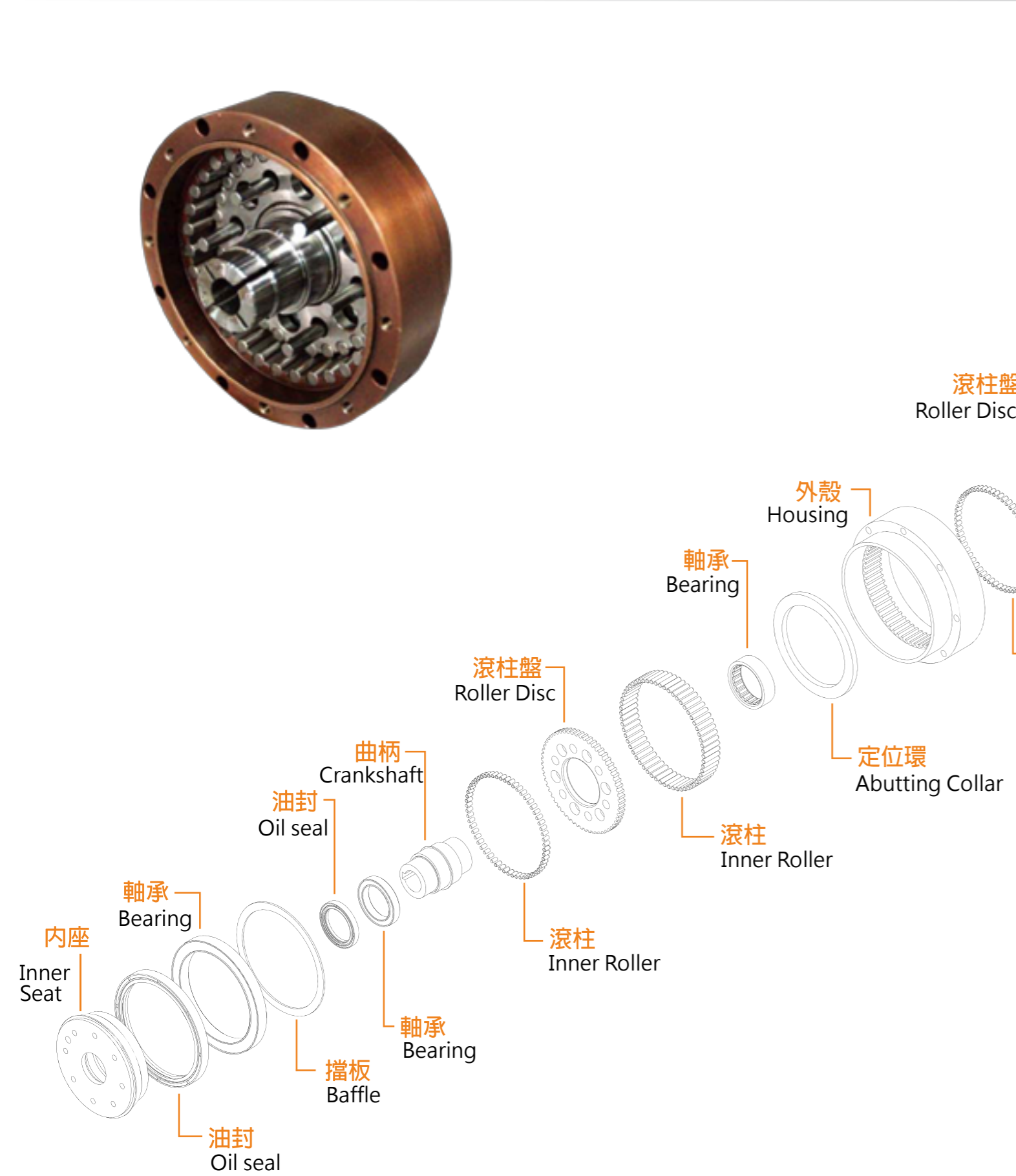

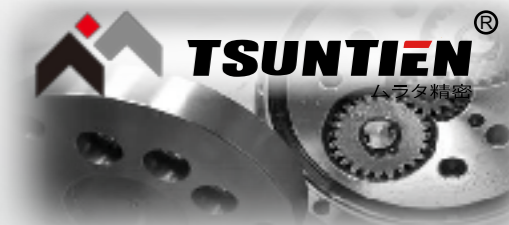

### ● TTRA Series

適用於變位機·刀塔·工具機以及伺服馬達需直結於減速機中的機台與機構·TTRA最大的特點是擁有直結的輸出·緊固的鎖固·並能保證精度。

TTRA series is suitable to be applied to positioner, turret, tooling machine and automatic mechanism connected with servo motor. The features of TTRA series are direct output, tightening engagement and high accuracy.



### ● TTRD-C Series

因應市場機械的需要·許多機台以及機械手臂的第一軸必須中空也希望伺服馬達能直結·我們特別開發出TTRD-C來解決這問題·成功的做到減速機中空並且伺服能直結·更能顯現應用的便利性。

To meet with the requirements of mechanism and robot arms with hollow-designed and to be connected to the servo motor directly. TTRD-C series is designed to solve this problem by hollow-body and successfully connected to the servo motor directly, which provide more convenient and application-friendly.



### ● TTRV Series

此系列專為機械手臂開發·而TTRV擁有輕盈的機身·薄型的身長大大的減少機械手臂轉動的慣性使其定位更佳的精準。

TTRV series is developed for robotic industries. The compact and light weight could reduce the inertia of robot swing to achieve more precise positioning.



### ● TTRV-C Series

許多設計師因空間關係·管線無法存放甚至做動時拉扯到管線·這款TTRV-C將可以排除這個困難·因機身為中空可讓管線通過避免了機械做動時的管線拉扯。

Many designers face problem that the cable operation was restrained due to limited space. The hollow body design of TTRV-C series allows cable to get through without obstruction.

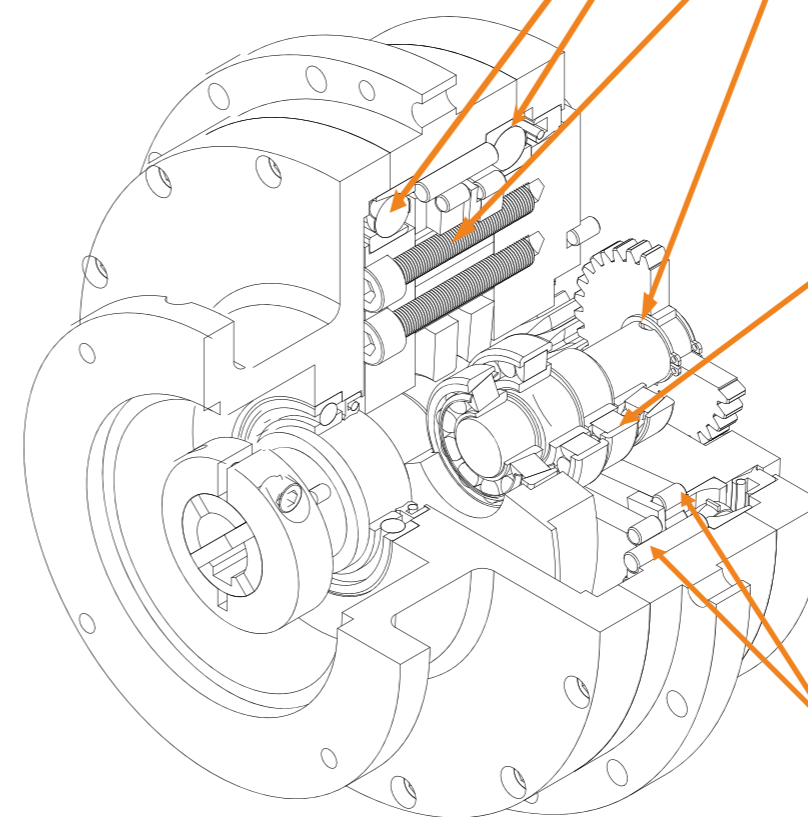

### ■ 主軸承內置機構 Main in-house Bearing Mechanism

可靠性高·成本降低·安裝有壓力角球軸承·允許彎矩大·可減少所需的零件數量·安裝方便。

High reliability · Low cost. With Pressure angular ball bearings enable larger bending moment, less components and easy to install.

### ■ 二段式減速機構 Two-stage Reduction Mechanism

振動小·圓滾柱的公轉速度變慢·振動較小·能夠減少電機直結部(輸入齒輪)·慣性減少。

Slight vibration. Revolution of cylindrical rollers become slower meantime obtain slight vibration, enabled to select smaller motor (input gear) and lower inertia.

### ■ 滾動接觸機構 Internal and External Rollers Mechanism

齒隙小(1 arc-min)·耐磨性高·噪音較低·同時多齒啮合·穩定較高。

Low backlash (1 arc-min). High resistance, low noise, multi-teeth engagement and better stability.

### ■ 內、外滾柱機構 Rolling Contact Mechanism

啟動效率優異·磨耗小·壽命較長·齒隙小(1 arc-min)·使用圓柱滾子軸承。

High start-up efficiency, High resistance, Long service life, Low backlash (1 arc-min). Cylinder roller bearing used.



變位機  
Positioner



機械人底部軸  
Base of Robot



碼垛機械人  
Robot Palletizer



專用自動化設備  
Automation Equipment



自動彎管設備  
Bender



自動貼標印刷機  
Label Printing Machine



工具機第四軸與第五軸  
The Fourth and Fifth Axis of Machine tools.



沖壓機械手  
Punching Machine



搬運機器人  
Transfer Robot



焊接機械人與輔機  
Welding Robot and Auxiliary

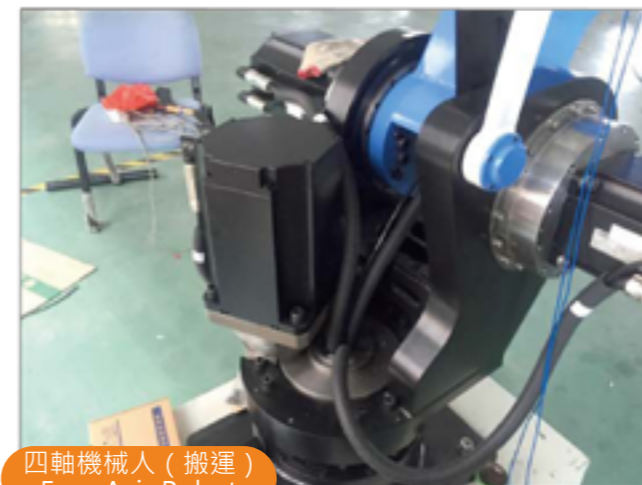

四軸機械人 (搬運)  
Four Axis Robot



蜘蛛型機械人  
Spider type Robot



六軸機械人  
Six Axis Robot



六軸機械人  
Six Axis Robot

# TTRA-E 系列

## TTRA-E Series



### 直結的輸出，緊固的鎖固，並能保證精度

適用於變位機，刀塔，工具機以及伺服馬達需直結於減速機中的機台與機構

Direct output, tightening engagement and high accuracy.

TTRA series is suitable to be applied to positioner, turret, tooling machine and automatic mechanism connected with servo motor.

- 型 式：TTRA-5E ~ TTRA-450E
- 背 隙：≤1-5弧分
- 減速比：1/35 ~ 1/140
- 容 量：0.1KW ~ 15KW
- 轉動方式：軸轉動 or 殼轉動
- 額定輸出扭矩：60NM ~ 5100NM

- Type : TTRA-5E ~ TTRA-450E
- Backlash : ≤1-5 Arc.min
- Ratio : 1/35 ~ 1/140
- Capacity : 0.1KW ~ 15KW
- Rotation : Shaft Run or Case Run
- Rated output torque : 60NM ~ 5100NM

# TTRA-E 訂購說明

## TTRA-E Ordering Instructions

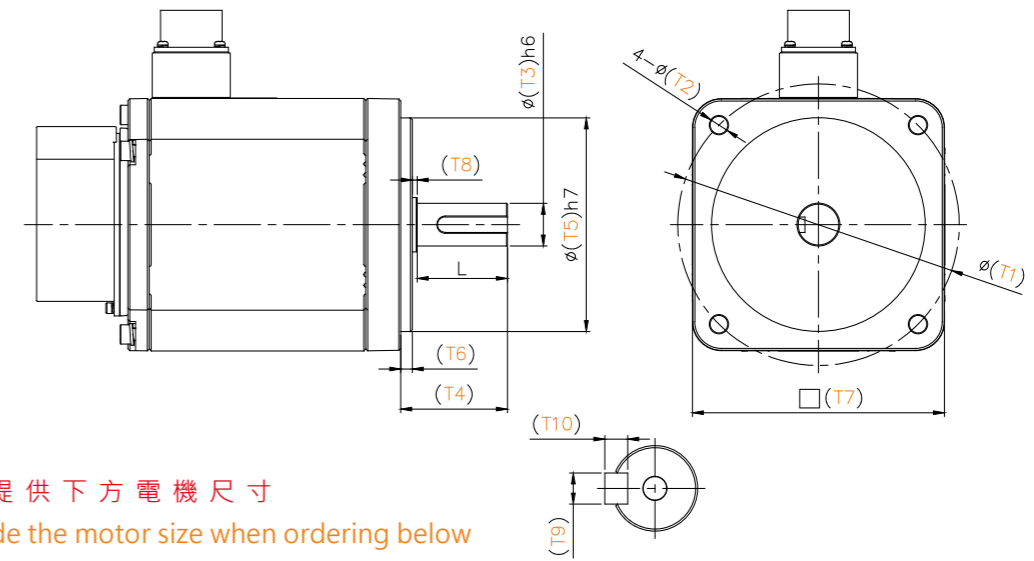

訂購時請提供下方電機尺寸  
Please provide the motor size when ordering below

馬達廠牌 Motor Brand :					
馬達型號 Motor Model :					
T1	T2	T3	T4	T5	T6
螺絲孔中心距 P.C.D	螺絲孔直徑 Bolt Hole Diameter	馬達軸外徑 Motor Shaft Diameter	馬達軸長度 Motor shaft length	馬達凸緣外徑 Motor Pilot Diameter	馬達緣高度 Motor Pilot Height
T7	L	T8		T9	T10
馬達面尺寸 Motor Flange Cross Section Output	馬達軸有效長 Motor Shaht Lenght	非安川免填 Diameter required when using YASKAWA made motor		鍵 寬 Key Width	鍵 高 Key Thickness

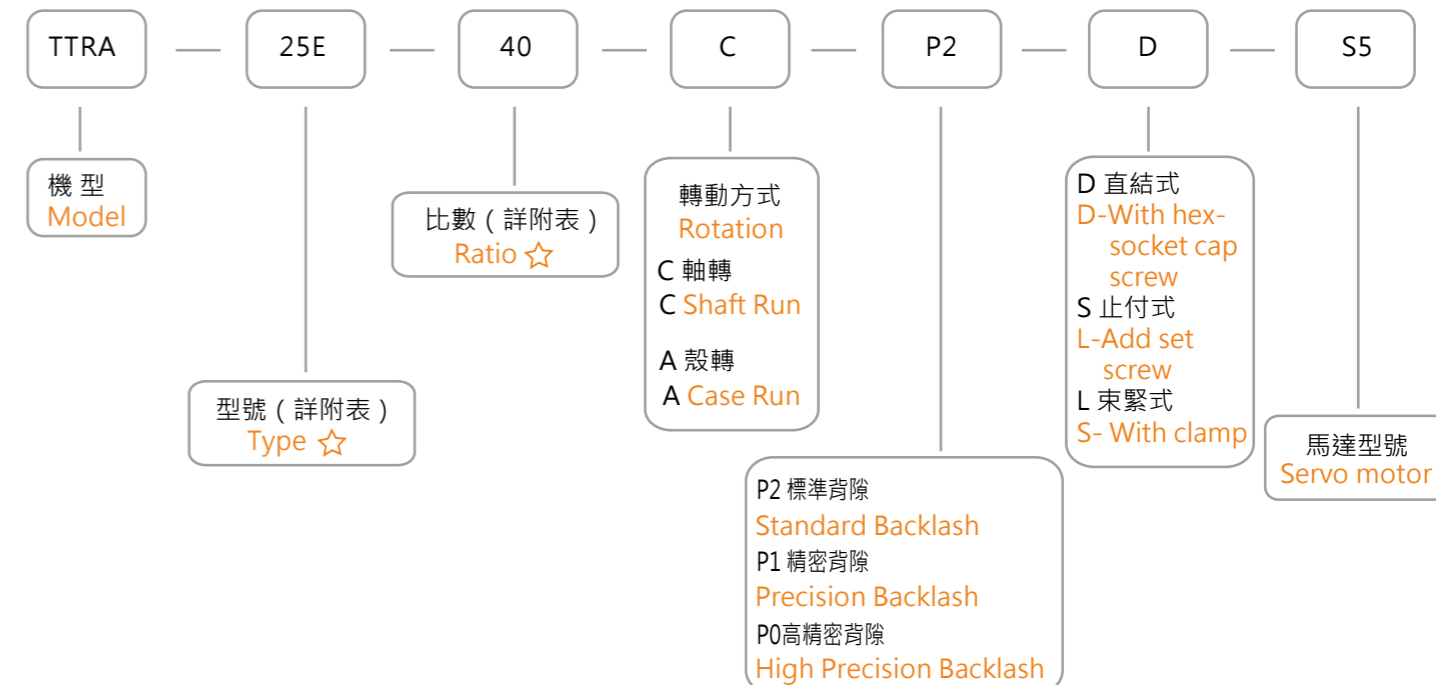

# 安裝方式選項:

## Motor mounting selections:

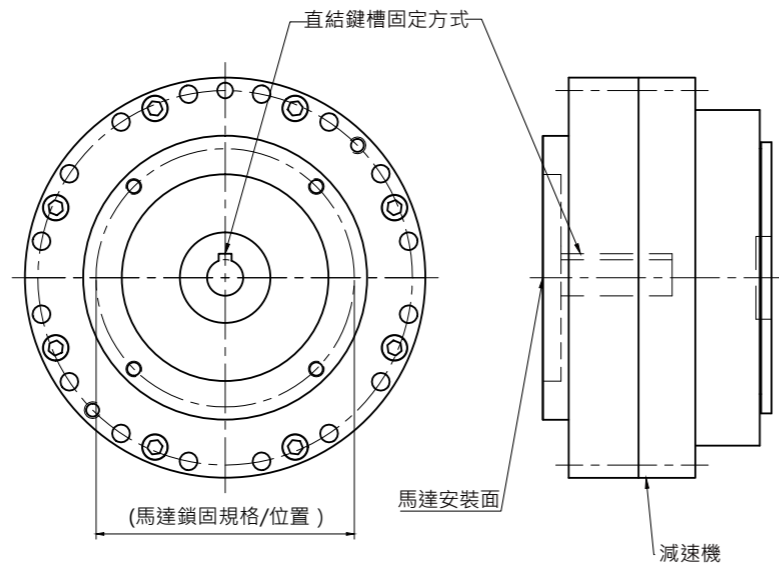
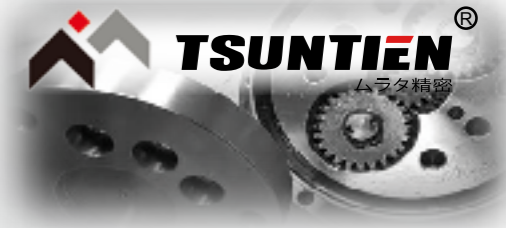

### ● D-直結式

D-With hex-socket cap screw:

- 1.馬達軸心鍵與減速機入力軸鍵槽對齊置入。
- 2.馬達與減速機結合後將馬達上4根螺絲鎖緊即可。

1. Place motor shaft key and gearbox input shaft key way in a straight line, and insert motor shaft into gearbox input shaft.
2. After connection of motor and gear box, tighten four screws into hex-socket cap screw holes.

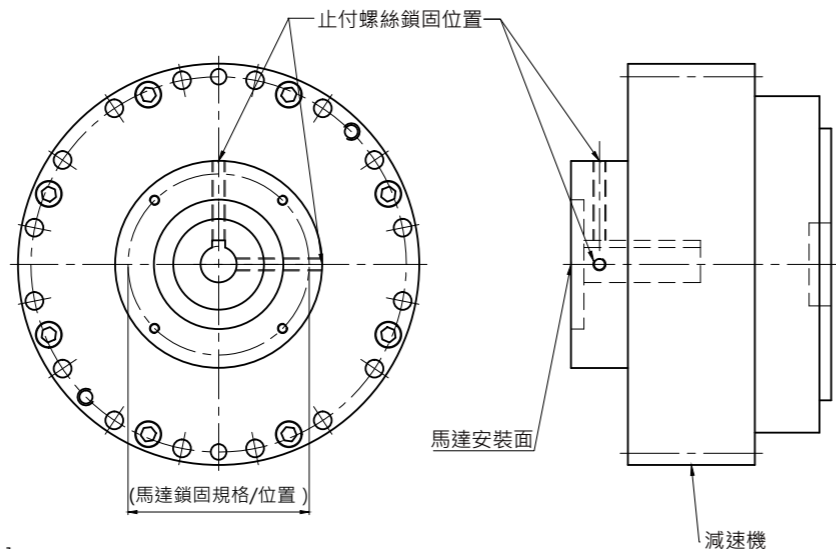

### ● L-止付式

L-Add set screw:

- 1.馬達軸心鍵與減速機入力軸鍵槽對齊置入。
- 2.馬達與減速機結合後將馬達上4根螺絲鎖緊。
- 3.使用T型扳手將減速機入力軸內的止付螺絲鎖緊即可。

1. Place motor shaft key and gearbox input shaft key way in a straight line, and insert motor shaft into gearbox input shaft.
2. After connection of motor and gear box, tighten four screws into hex-socket cap screw holes.
3. Fix the set screw on gearbox input shaft by T-type spanner.

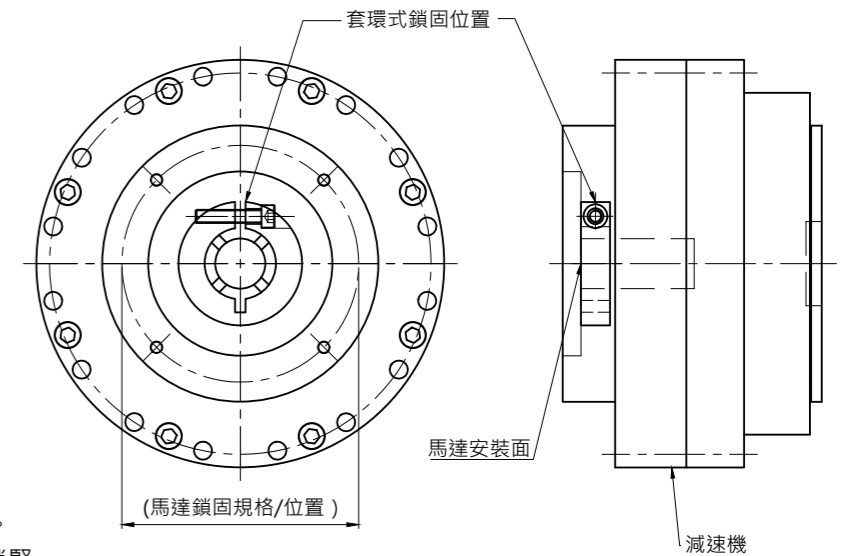

### ● S-束緊式:

S-With clamp

- 1.馬達軸心鍵與減速機入力軸鍵槽對齊置入。
- 2.馬達與減速機結合後，將馬達上4根螺絲鎖緊。
- 3.使用T型扳手將入力軸束緊環鎖緊即可。

1. Place motor shaft key and gearbox input shaft key way in a straight line, and insert motor shaft into gearbox input shaft.
2. After connection of motor and gear box, tighten four screws into hex-socket cap screw holes.
3. Tighten the clamp of gearbox input shaft by T-type spanner.

# TTRA-E 性能表

## TTRA-E Technical Specification Table

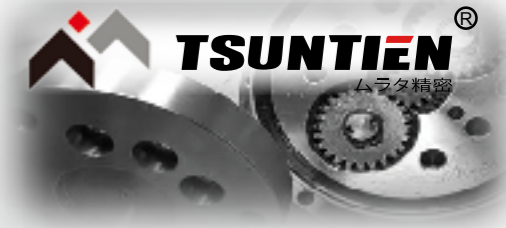

Specification 規格		TTRA-E Technical Specification Table					
Rotation 轉動方式		TTRA-5E		TTRA-7E		TTRA-25E	
		Shaft Run 軸轉動	Case Run 殼轉動	Shaft Run 軸轉動	Case Run 殼轉動	Shaft Run 軸轉動	Case Run 殼轉動
Ratio 減速比		30	31	40	41	40	41
		40	41	50	51	50	51
		50	51	59	60	59	60
		-	-	-	-	-	-
		-	-	-	-	-	-
Rated Output Torque 額定輸出扭矩	NM kgf-m	60 (6.1)		83 (8.46)		245 (25)	
Acceleration & Braking Torque 加速和制動扭矩	NM kgf-m	97.5 (9.9)		136 (14)		515 (52)	
Instantaneous Max. Allowable Torque 瞬間最大容許轉矩	NM kgf-m	245 (25)		415 (42)		1000 (102)	
Ratrd Input Speed 額定輸入轉速	NR (rpm)	2000		2000		2000	
Ratrd Lifetime 額定壽命	Hr	6000		6000		6000	
Allowable Max. Input Speed 瞬間容許最高輸出轉速	Min (rpm)	3000		3000		3000	
Tilting Stiffness 傾斜鋼度	Nm(arc.min) kgf-m(arc.min)	82 (8.3)		117 (12)		372 (38)	
Torsional Stiffness 扭轉鋼度	Nm(arc.min) kgf-m(arc.min)	18 (1.83)		20 (2)		49 (5)	
Max.Lost Motion 最大無效行程	(arc.min)	<3.0		<3.0		<2.0	
Angular Transmission Error 扭轉傳輸中角度偏移量	ATE (arc.sec)	40		80		40	
Backlash 間隙	Standard Backlash 標準背隙	<5.0		<5.0		<5.0	
	Precision Backlash 精密背隙	<3.0		<3.0		<3.0	
	High Precision Backlash 超精密背隙	-		-		-	
Maximum Tilting Moment 最大傾斜力矩	NM kgf-m	282 (28.8)		392 (40)		1764 (180)	
Rated Radial Force 額定徑向力	N/M	118		196		882	
Max. Axial Force 最大軸向推力	N	885		1470		3920	
Inertia Of Bending Moment 慣性彎矩 (I=GD <sup>2</sup> /4)	Input Inertial Kg-m <sup>2</sup> 輸入慣量	-		2.60×10 <sup>-6</sup>		1.08×10 <sup>-5</sup>	
		1.65×10 <sup>-6</sup>		1.85×10 <sup>-6</sup>		0.65×10 <sup>-5</sup>	
		1.46×10 <sup>-6</sup>		1.66×10 <sup>-6</sup>		0.45×10 <sup>-5</sup>	
		-		-		-	
Weight 重量	KG	1.5		4.5		8.5	

PS:需要上述速比之外的減速比時，請洽詢本公司，電機轉速超出額定輸入轉速時，運轉噪音將會提高，請注意減速機容許負載使用表面溫度需低於70°C。

Please contact us for other ratio selections. Please be noted that the noise will be increased when the input speed (RPM:revolution per minute)of motor is higher than rated input speed; the operating temperature and motor service temperature should be under 70°C.

TTRA-E Technical Specification Table												
		TTRA-45E		TTRA-135E		TTRA-165E		TTRA-325E		TTRA-450E		TTRA-700E
		Shaft Run 軸轉動	Case Run 殼轉動	Shaft Run 軸轉動	Case Run 殼轉動	Shaft Run 軸轉動	Case Run 殼轉動	Shaft Run 軸轉動	Case Run 殼轉動	Shaft Run 軸轉動	Case Run 殼轉動	-
Ratio 減速比		35	36	50	51	50	51	59	60	59	60	-
		40	41	60	61	59	60	79	80	79	80	
		50	51	79	80	79	80	99	100	99	100	
		59	60	99	100	99	100	119	120	119	120	
		79	80	-	-	-	-	139	140	139	140	
		460 (46.8)		1400 (136)		1615 (165)		3595 (366)		5100 (520)		-
		1158 (118)		2083 (212)		4043 (412)		7963 (812)		11025 (1125)		-
		2300 (234.4)		4155 (423.5)		8075 (823)		17975 (1830)		25500 (2600)		-
		2000		2000		1500		1500		1500		-
		6000		6000		6000		6000		6000		-
		3000		2500		2500		2000		2000		-
		931 (95)		1176 (120)		2940 (300)		4900 (500)		7448 (760)		-
		108 (11)		196 (20)		392 (40)		980 (100)		1176 (120)		-
		<2.0		<1.5		<1.5		<1.5		<1.5		-
		40		40		40		40		40		-
		<5.0		<4.0		<4.0		<4.0		<4.0		-
		<3.0		<2.0		<2.0		<2.0		<2.0		-
		<1.0		<1.0		<1.0		<1.0		<1.0		-
		3332 (340)		4312 (440)		7840 (800)		14112 (1440)		17640 (1800)		-
		1666		2156		3920		7056		8820		-
		5194		7840		14700		19600		24500		-
		4.50×10 <sup>-5</sup>		5.65×10 <sup>-5</sup>		1.9×10 <sup>-4</sup>		6×10 <sup>-4</sup>		9×10 <sup>-4</sup>		-
		3.75×10 <sup>-5</sup>		4.40×10 <sup>-5</sup>		1.8×10 <sup>-4</sup>		5.4×10 <sup>-4</sup>		7.3×10 <sup>-4</sup>		-
		2.4×10 <sup>-5</sup>		3.53×10 <sup>-5</sup>		1.78×10 <sup>-4</sup>		4×10 <sup>-4</sup>		6×10 <sup>-4</sup>		-
		1.75×10 <sup>-5</sup>		2.63×10 <sup>-5</sup>		1.51×10 <sup>-4</sup>		2.8×10 <sup>-4</sup>		4.8×10 <sup>-4</sup>		-
		2.4×10 <sup>-5</sup>		-		-		1.8×10 <sup>-4</sup>		4.2×10 <sup>-4</sup>		-
		12		32		36		65		81		-

# TTRA-E 尺寸圖

## Drawing & Dimension



### TTRA-5E-□

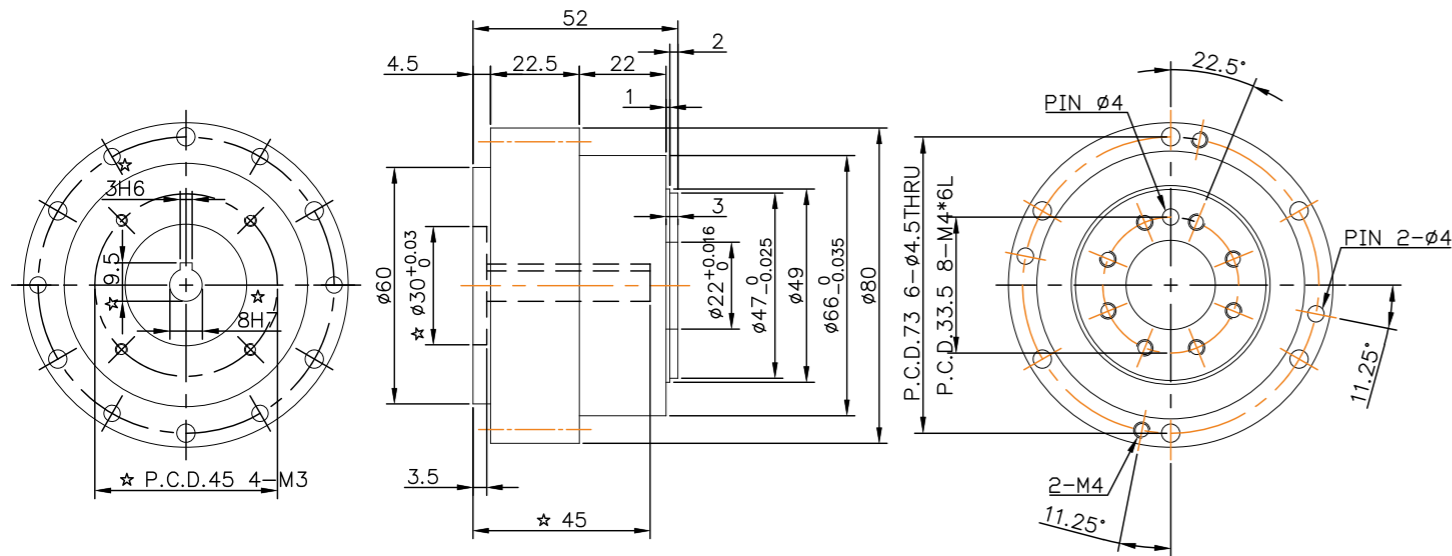

1. ☆ 會隨伺服馬達不同有所變更
2. 本機軸心可從φ8~φ11
3. 此圖為軸心轉動·殼轉動圖請洽詢本公司

1. "☆" the dimensions alter with motor specification.
2. Output shaft diameter: φ8~φ11 mm.
3. This drawing is model of shaft rotation, for shell rotation drawing, please contact us.

### TTRA-7E-□

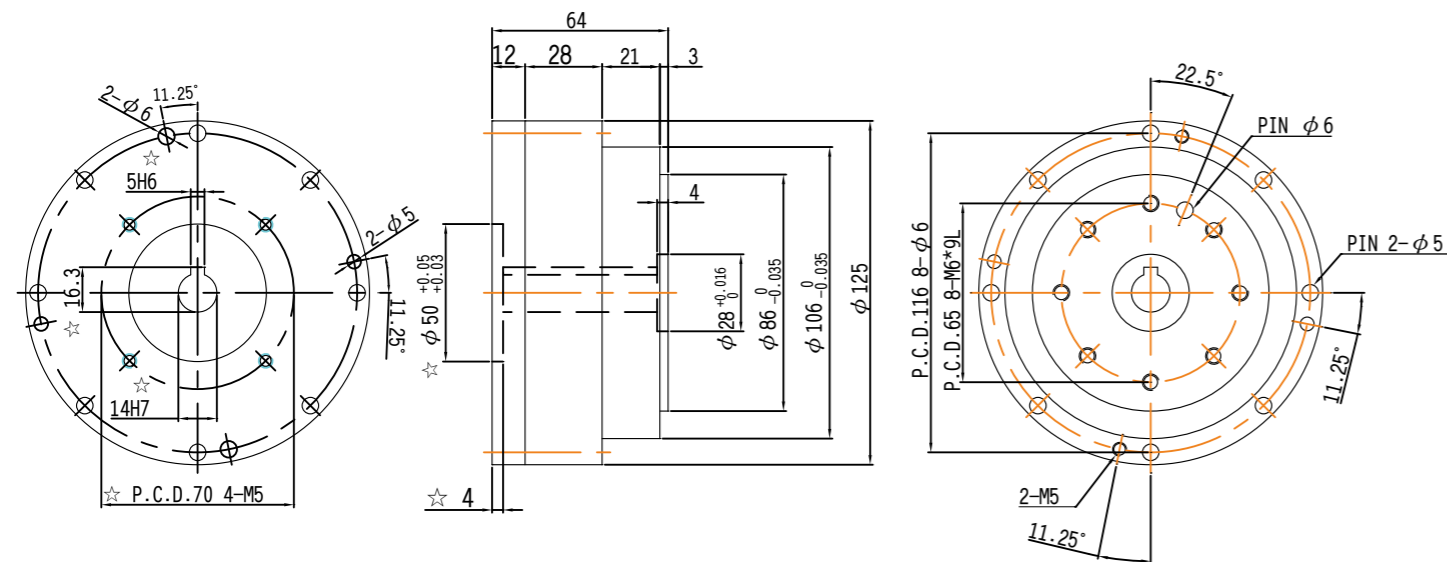

1. ☆ 會隨伺服馬達不同有所變更
2. 本機軸心可從φ11~φ19
3. 此圖為軸心轉動·殼轉動圖請洽詢本公司

1. "☆" the dimensions alter with motor specification.
2. Output shaft diameter: φ11~φ19 mm.
3. This drawing is model of shaft rotation, for shell rotation drawing, please contact us.

### TTRA-25E-□

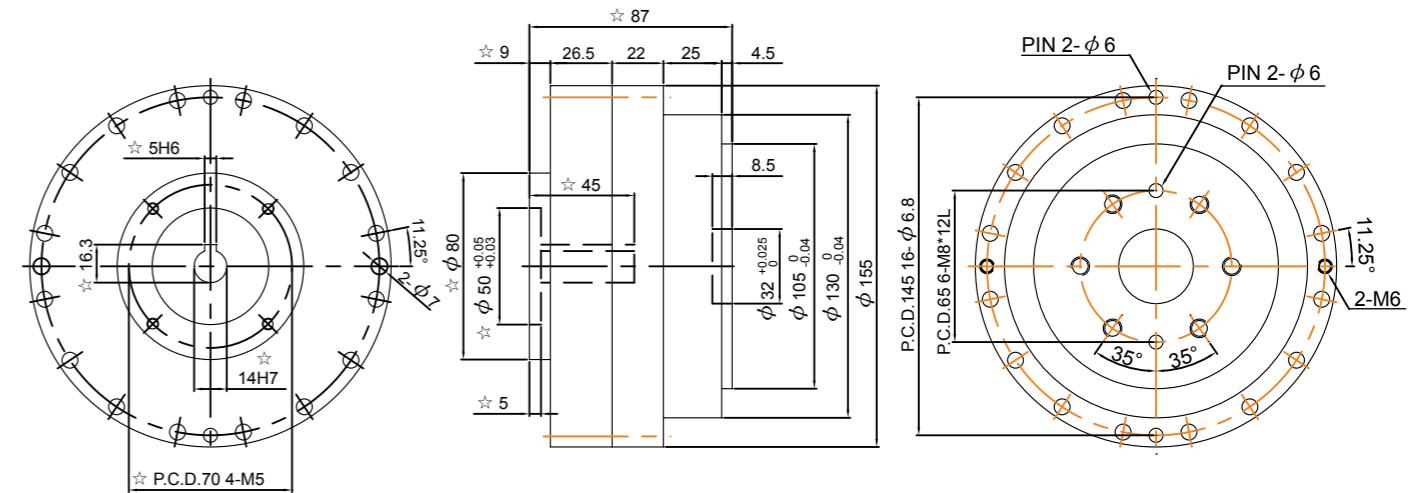

1. ☆ 會隨伺服馬達不同有所變更
2. 本機軸心可從φ11~φ24
3. 此圖為軸心轉動·殼轉動圖請洽詢本公司

1. "☆" the dimensions alter with motor specification.
2. Output shaft diameter: φ11~φ24 mm.
3. This drawing is model of shaft rotation, for shell rotation drawing, please contact us.

### TTRA-45E-□

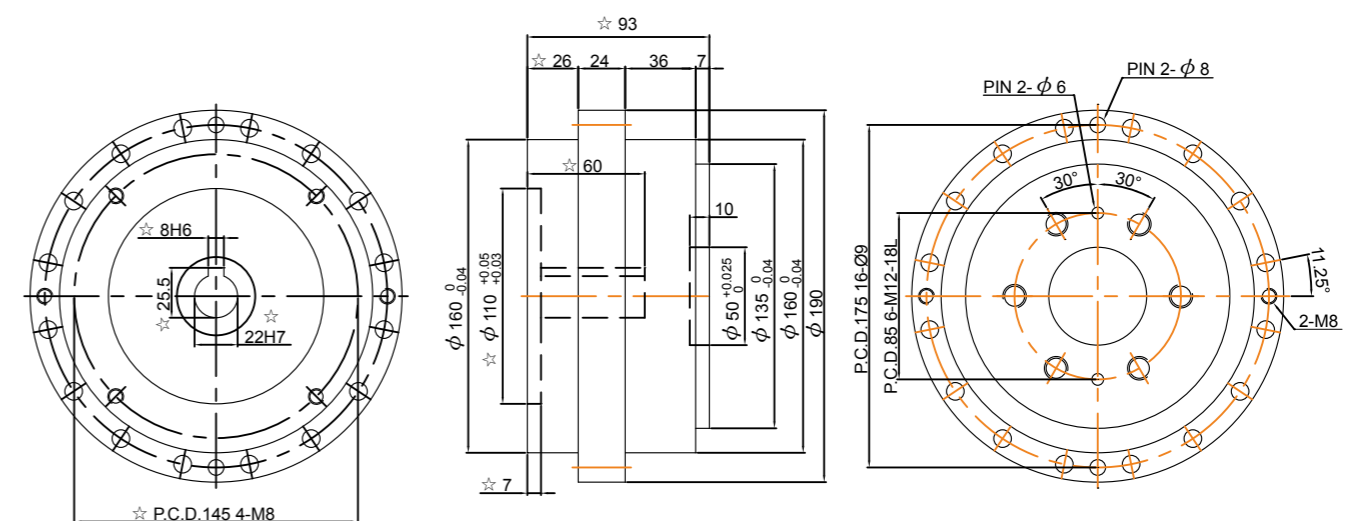

1. ☆ 會隨伺服馬達不同有所變更
2. 本機軸心可從φ14~φ28
3. 此圖為軸心轉動·殼轉動圖請洽詢本公司

1. "☆" the dimensions alter with motor specification.
2. Output shaft diameter: φ14~φ28 mm.
3. This drawing is model of shaft rotation, for shell rotation drawing, please contact us.



# TTRAD-E 系列

## TTRAD-E Series

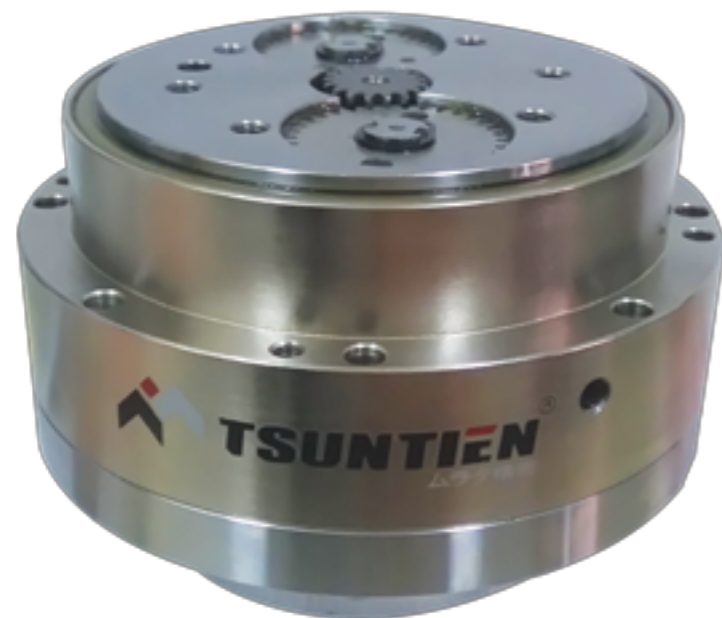

- 型 式 : TTRAD-7E ~ TTRAD-450E
- 背 隙 :  $\leq 1-3$  弧分
- 減速比 : 1/78 ~ 1/361
- 容 量 : 0.2KW ~ 15KW
- 轉動方式 : 軸轉動 or 殼轉動
- 額定輸出扭矩 : 83NM ~ 5100NM

- Type : TTRAD-7E ~ TTRAD-450E
- Backlash :  $\leq 1-3$  Arc.min
- Ratio : 1/78 ~ 1/361
- Capacity : 0.2KW ~ 15KW
- Rotation : Shaft Run or Case Run
- Rated output torque : 83NM ~ 5100NM

# TTRAD-E 訂購說明

## TTRAD-E Ordering Instructions

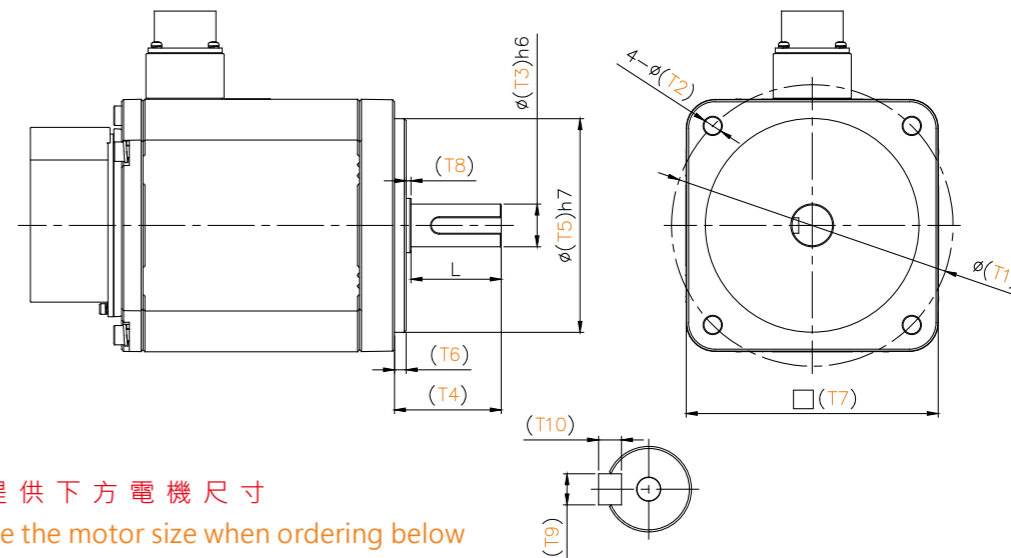

訂購時請提供下方電機尺寸

Please provide the motor size when ordering below

馬達廠牌 Motor Brand :					
馬達型號 Motor Model :					
T1	T2	T3	T4	T5	T6
螺絲孔中心距 P.C.D	螺絲孔直徑 Bolt Hole Diameter	馬達軸外徑 Motor Shaft Diameter	馬達軸長度 Motor shaft length	馬達凸緣外徑 Motor Pilot Diameter	馬達緣高度 Motor Pilot Height
T7	L	T8		T9	T10
馬達面尺寸 Motor Flange Cross Section Output	馬達軸有效長 Motor Shaht Lenght	非安川免填 Diameter required when using YASKAWA made motor		鍵 寬 Key Width	鍵 高 Key Thickness

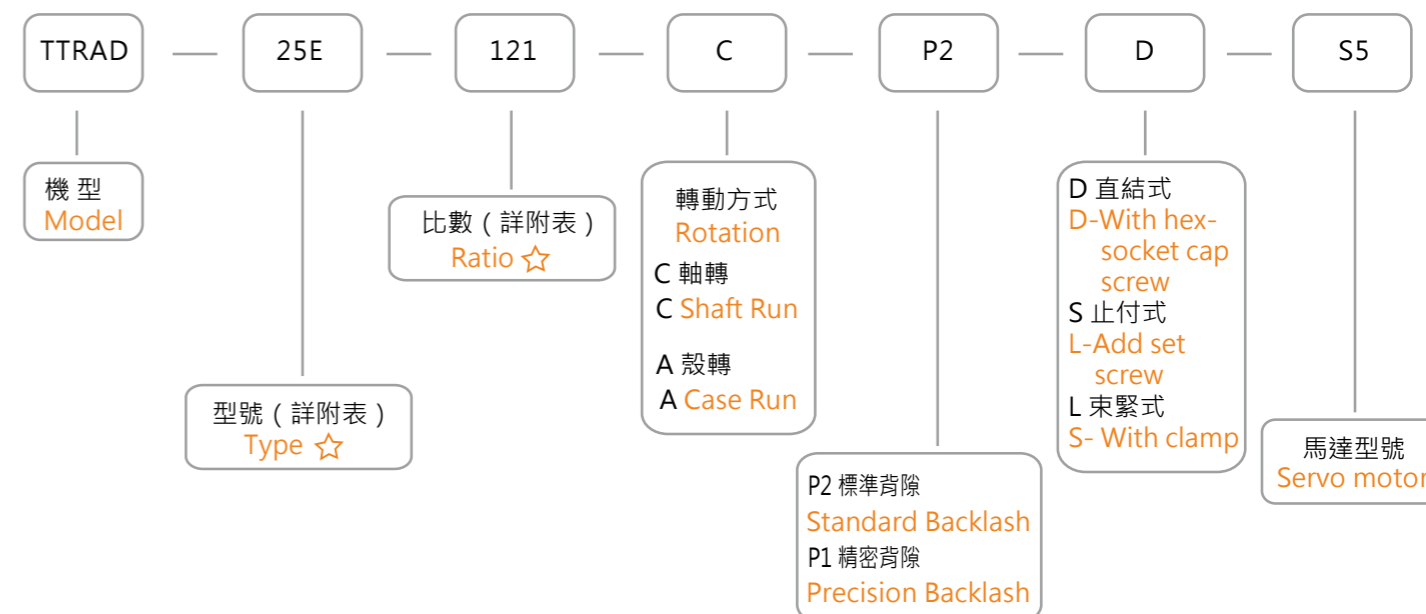

# 安裝方式選項:

## Motor mounting selections:

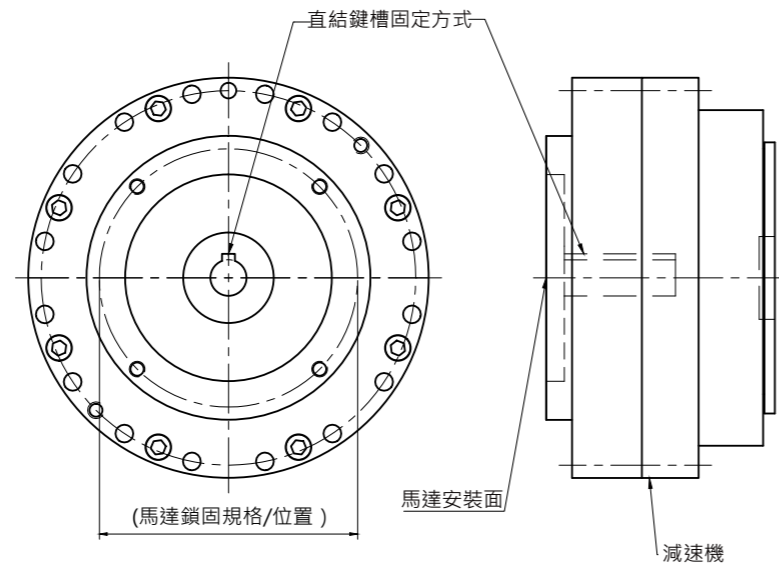
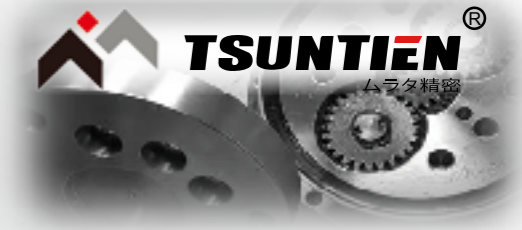

### ● D-直結式

D-With hex-socket cap screw:

1. 馬達軸心鍵與減速機入力軸鍵槽對齊置入。
2. 馬達與減速機結合後將馬達上4根螺絲鎖緊即可。

1. Place motor shaft key and gearbox input shaft key way in a straight line, and insert motor shaft into gearbox input shaft.
2. After connection of motor and gear box, tighten four screws into hex-socket cap screw holes.

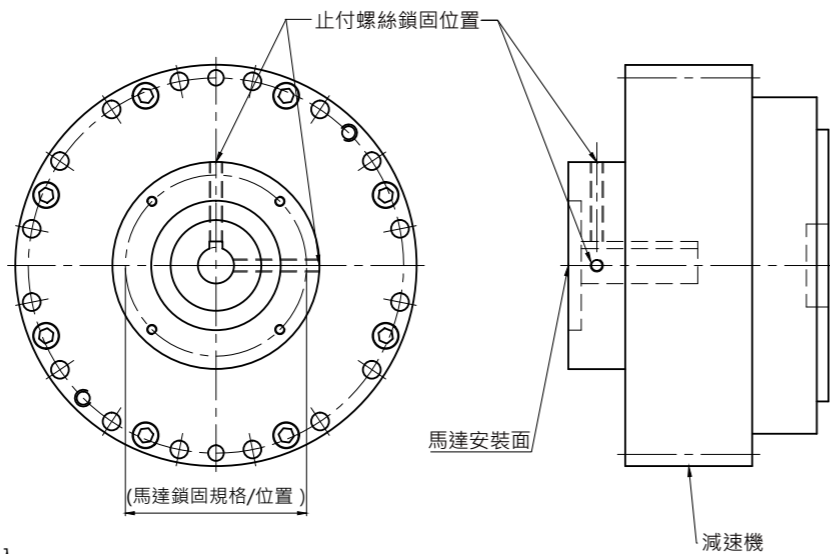

### ● L-止付式

L-Add set screw:

1. 馬達軸心鍵與減速機入力軸鍵槽對齊置入。
2. 馬達與減速機結合後將馬達上4根螺絲鎖緊。
3. 使用T型扳手將減速機入力軸內的止付螺絲鎖緊即可。

1. Place motor shaft key and gearbox input shaft key way in a straight line, and insert motor shaft into gearbox input shaft.
2. After connection of motor and gear box, tighten four screws into hex-socket cap screw holes.
3. Fix the set screw on gearbox input shaft by T-type spanner.

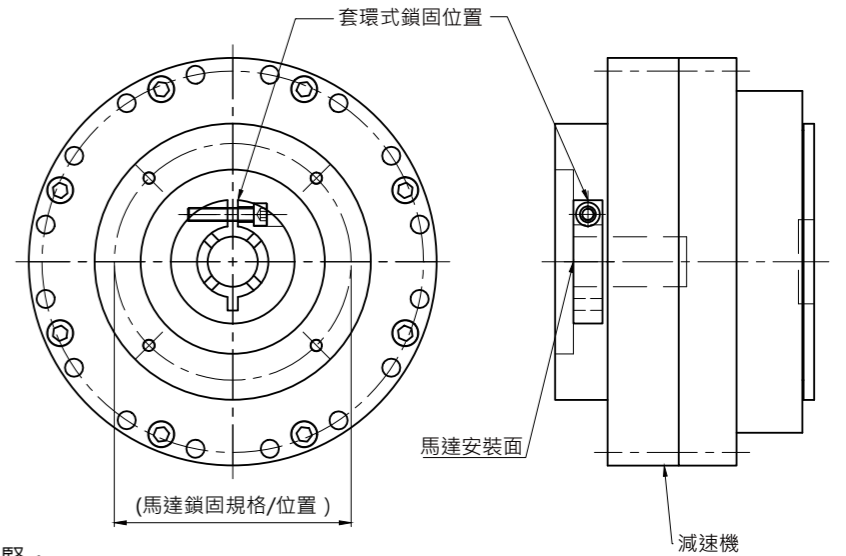

### ● S-束緊式:

S-With clamp

1. 馬達軸心鍵與減速機入力軸鍵槽對齊置入。
2. 馬達與減速機結合後，將馬達上4根螺絲鎖緊。
3. 使用T型扳手將入力軸束緊環鎖緊即可。

1. Place motor shaft key and gearbox input shaft key way in a straight line, and insert motor shaft into gearbox input shaft.
2. After connection of motor and gear box, tighten four screws into hex-socket cap screw holes.
3. Tighten the clamp of gearbox input shaft by T-type spanner.

# TTRAD-E 性能表

## TTRAD-E Technical Specification Table



Specification 規格		TTRAD-E Technical Specification Table						TTRAD-E Technical Specification Table								
		TTRAD-7E		TTRAD-25E		TTRAD-45E		TTRAD-135E		TTRAD-165E		TTRAD-325E		TTRAD-450E		TTRAD-700E
Rotation 轉動方式		Shaft Run 軸轉動	Case Run 殼轉動	Shaft Run 軸轉動	Case Run 殼轉動	Shaft Run 軸轉動	Case Run 殼轉動	Shaft Run 軸轉動	Case Run 殼轉動	Shaft Run 軸轉動	Case Run 殼轉動	Shaft Run 軸轉動	Case Run 殼轉動	Shaft Run 軸轉動	Case Run 殼轉動	-
Ratio 減速比		83	82	83	82	79	78	103	102	103	102	121	120	181	180	-
		103	102	103	102	124	123	123	122	161	160	201	200	241	240	
		121	120	123	122	181	180	161	160	201	200	241	240	301	300	
		-	-	161	160	241	240	201	200	241	240	281	280	361	360	
Rated Output Torque 額定輸出扭矩	NM kgf-m	83 (8.46)		245 (25)		460 (46.8)		1400 (136)		1615 (165)		3595 (366)		5100 (520)		-
Acceleration & Braking Torque 加速和制動扭矩	NM kgf-m	136 (14)		515 (52)		1158 (118)		2083 (212)		4043 (412)		7963 (812)		11025 (1125)		-
Instantaneous Max. Allowable Torque 瞬時最大容許轉矩	NM kgf-m	415 (42)		1000 (102)		2300 (234.4)		4155 (423.5)		8075 (823)		17975 (1830)		25500 (2600)		-
Ratrd Input Speed 額定輸入轉速	NR (rpm)	1500		1500		1500		1500		1500		1500		1500		-
Ratrd Lifetime 額定壽命	Hr	6000		6000		6000		6000		6000		6000		6000		-
Allowable Max. Input Speed 瞬時容許最高輸出轉速	Min (rpm)	3000		2500		2500		2000		2000		2000		2000		-
Tilting Stiffness 傾斜鋼度	Nm(arc.min) kgf-m(arc.min)	117 (12)		372 (38)		931 (95)		1176 (120)		2940 (300)		4900 (500)		7448 (760)		-
Torsional Stiffness 扭轉鋼度	Nm(arc.min) kgf-m(arc.min)	20 (2)		49 (5)		108 (11)		196 (20)		392 (40)		980 (100)		1176 (120)		-
Max.Lost Motion 最大無效行程	(arc.min)	<2.0		<1.0		<1.0		<1.0		<1.0		<1.0		<1.0		-
Angular Transmission Error 扭轉傳輸中角度偏移量	ATE (arc.sec)	80		40		40		40		40		40		40		-
Backlash 間隙	Standard Backlash 標準背隙	(arc.min)	<3.0	<3.0	<3.0	<3.0	<3.0	<3.0	<3.0	<3.0	<3.0	<3.0	<3.0	<3.0	<3.0	-
	Precision Backlash 精密背隙		<2.0	<1.0	<1.0	<1.0	<1.0	<1.0	<1.0	<1.0	<1.0	<1.0	<1.0	<1.0		
Maximum Tilting Moment 最大傾斜力矩	NM kgf-m	392 (40)		1764 (180)		3332 (340)		4312 (440)		7840 (800)		14112 (1440)		17640 (1800)		-
Rated Radial Force 額定徑向力	N/M	196		882		1666		2156		3920		7056		8820		-
Max. Axial Force 最大軸向推力	N	1470		3920		5194		7840		14700		19600		24500		-
Inertia Of Bending Moment 慣性彎矩 (I=GD <sup>2</sup> /4)	Input Inertial Kg-m <sup>2</sup> 輸入慣量	1.42×10 <sup>-6</sup>	0.37×10 <sup>-5</sup>	1.12×10 <sup>-5</sup>	2.4×10 <sup>-5</sup>	1.0×10 <sup>-4</sup>	1.68×10 <sup>-4</sup>	3.8×10 <sup>-4</sup>								
		1.20×10 <sup>-6</sup>	0.29×10 <sup>-5</sup>	1.02×10 <sup>-5</sup>	2.2×10 <sup>-5</sup>	0.9×10 <sup>-4</sup>	1.6×10 <sup>-4</sup>	3.68×10 <sup>-4</sup>								
		0.9×10 <sup>-6</sup>	0.24×10 <sup>-5</sup>	0.8×10 <sup>-5</sup>	2.0×10 <sup>-5</sup>	0.8×10 <sup>-4</sup>	1.58×10 <sup>-4</sup>	3.5×10 <sup>-4</sup>								
		-	0.20×10 <sup>-5</sup>	0.7×10 <sup>-5</sup>	1.8×10 <sup>-5</sup>	0.7×10 <sup>-4</sup>	1.54×10 <sup>-4</sup>	2.3×10 <sup>-4</sup>								
		-	-	-	-	0.6×10 <sup>-4</sup>	1.5×10 <sup>-4</sup>	-								
Weight 重量	KG	5.5	12	18	34	50	76	76	-							

PS:需要上述速比之外的減速比時，請洽詢本公司，電機轉速超出額定輸入轉速時，運轉噪音將會提高，請注意減速機容許負載使用表面溫度需低於70°C。

Please contact us for other ratio selections. Please be noted that the noise will be increased when the input speed (RPM:revolution per minute)of motor is higher than rated input speed; the operating temperature and motor service temperature should be under 70°C.

# TTRAD-E 尺寸圖

## Drawing & Dimension



### TTRAD-7E-□-C-D

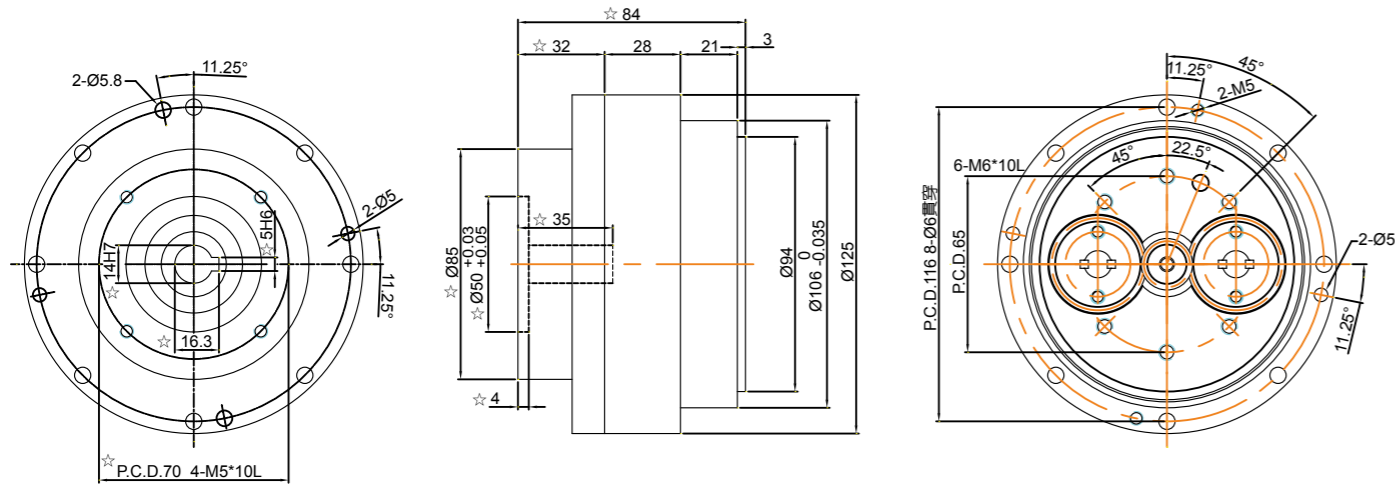

1. ☆ 會隨伺服馬達不同有所變更
2. 本機軸心可從φ11 ~ φ19
3. 此圖為軸心轉動 · 殼轉動圖請洽詢本公司

1. "☆" the dimensions alter with motor specification.
2. Output shaft diameter: Φ11~Φ19 mm.
3. This drawing is model of shell rotation, for shaft rotation drawing, please contact us.

### TTRAD-25E-□-C-D

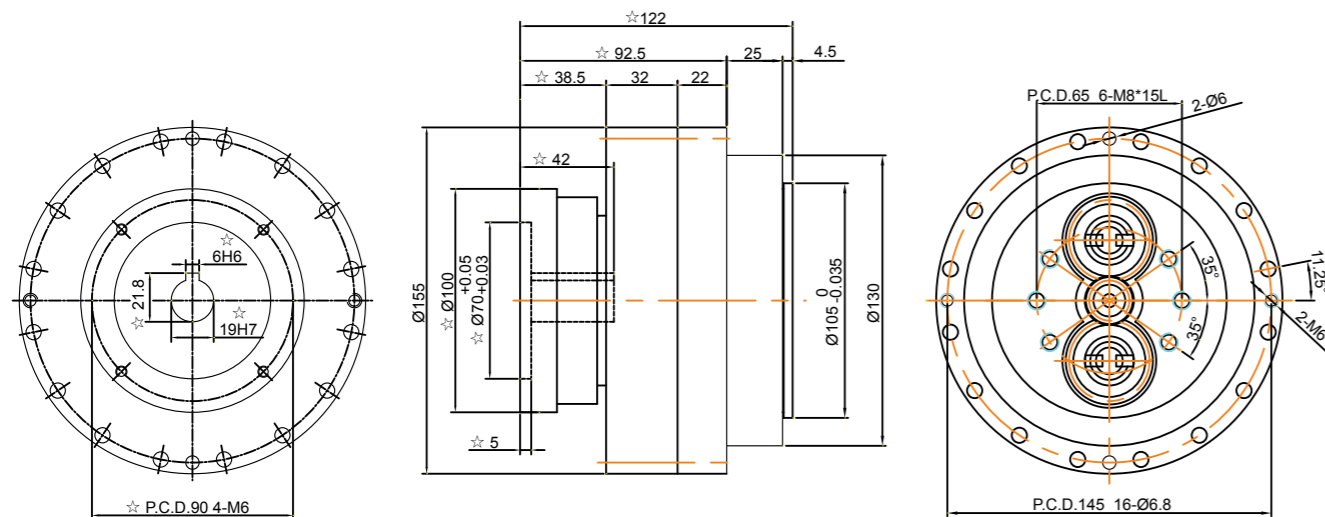

1. ☆ 會隨伺服馬達不同有所變更
2. 本機軸心可從φ11 ~ φ24
3. 此圖為軸心轉動 · 殼轉動圖請洽詢本公司

1. "☆" the dimensions alter with motor specification.
2. Output shaft diameter: Φ11~Φ24mm.
3. This drawing is model of shell rotation, for shaft rotation drawing, please contact us.

### TTRAD-45E-□-C-D

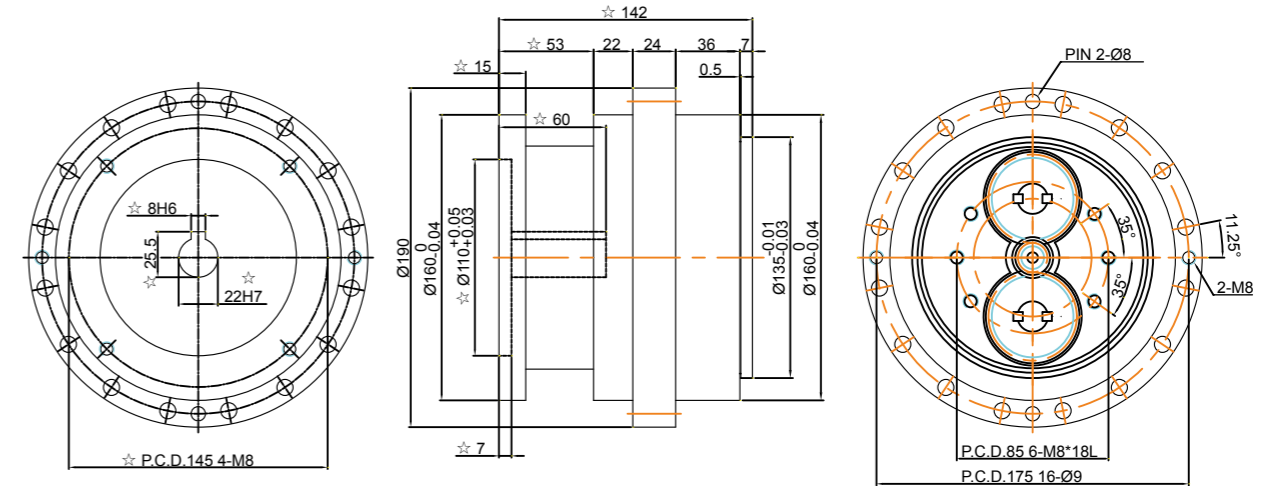

1. ☆ 會隨伺服馬達不同有所變更
2. 本機軸心可從φ14 ~ φ28
3. 此圖為軸心轉動 · 殼轉動圖請洽詢本公司

1. "☆" the dimensions alter with motor specification.
2. Output shaft diameter: Φ14~Φ28 mm.
3. This drawing is model of shell rotation, for shaft rotation drawing, please contact us.

### TTRAD-135E-□-C-D

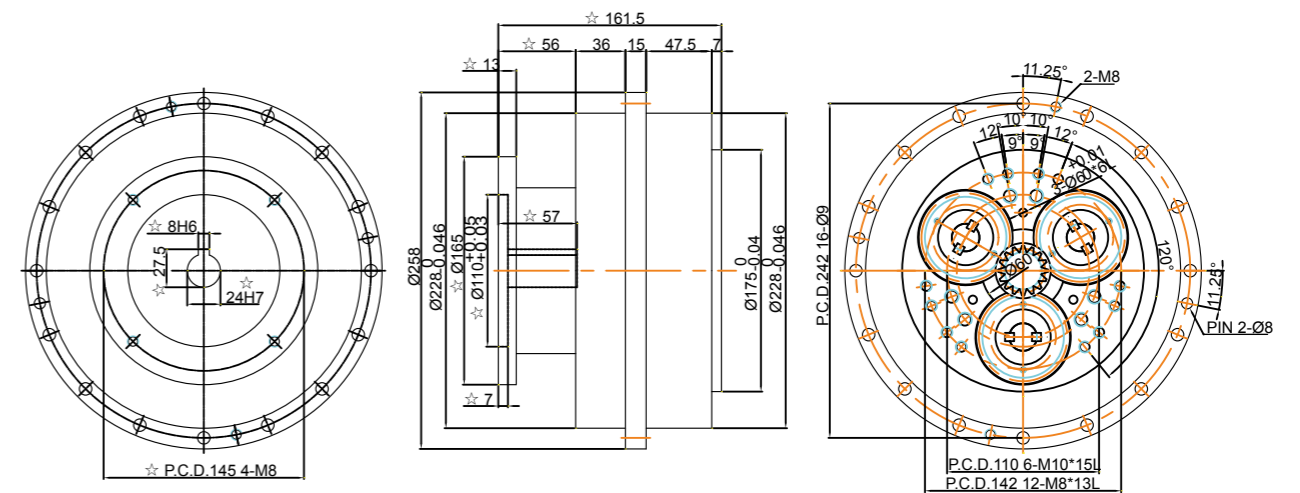

1. ☆ 會隨伺服馬達不同有所變更
2. 本機軸心可從φ19 ~ φ35
3. 此圖為軸心轉動 · 殼轉動圖請洽詢本公司

1. "☆" the dimensions alter with motor specification.
2. Output shaft diameter: Φ19~Φ35 mm.
3. This drawing is model of shell rotation, for shaft rotation drawing, please contact us.

# TTRAD-E 尺寸圖

## Drawing & Dimension



### TTRAD-165E-□-C-D

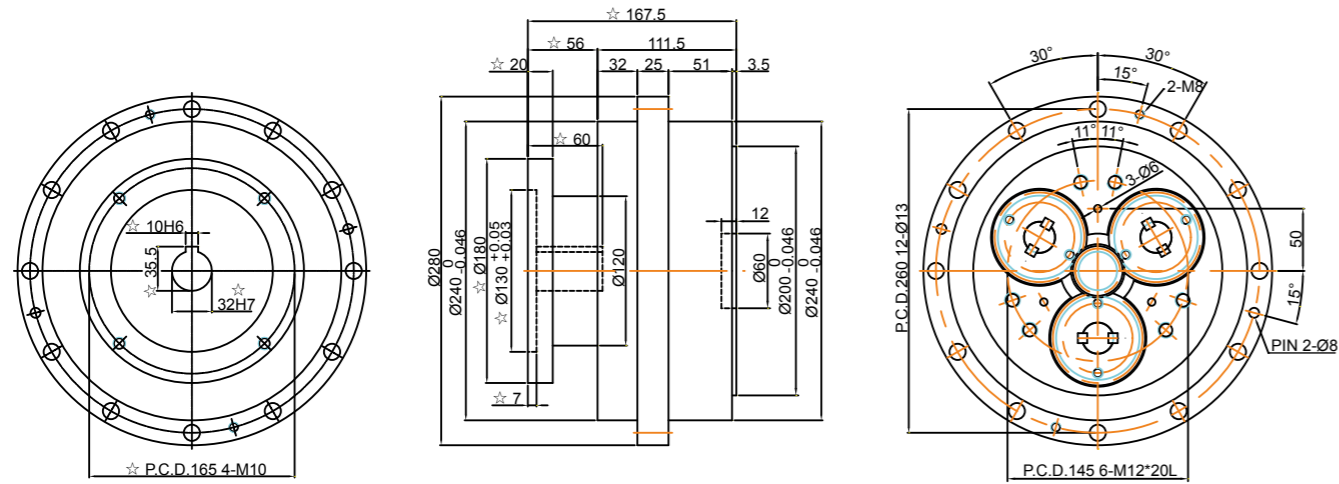

1. ☆ 會隨伺服馬達不同有所變更
2. 本機軸心可從 $\phi 22 \sim \phi 42$
3. 此圖為軸心轉動·殼轉動圖請洽詢本公司

1. "☆" the dimensions alter with motor specification.
2. Output shaft diameter:  $\phi 22 \sim \phi 42$  mm.
3. This drawing is model of shell rotation, for shaft rotation drawing, please contact us.

### TTRAD-325E-□-C-D

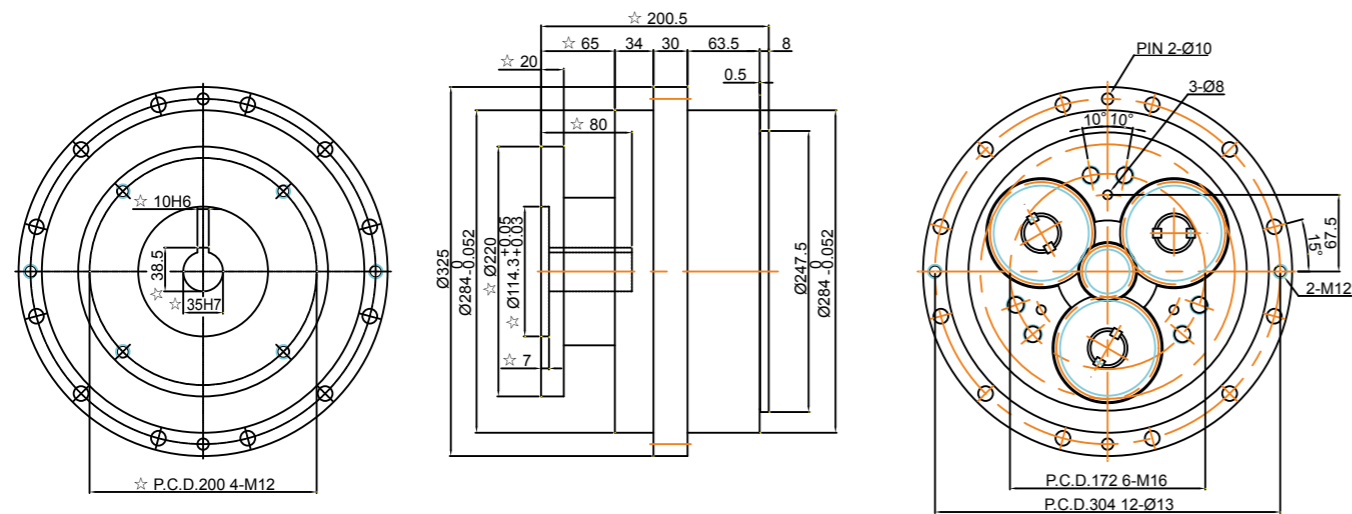

1. ☆ 會隨伺服馬達不同有所變更
2. 本機軸心可從 $\phi 24 \sim \phi 42$
3. 此圖為軸心轉動·殼轉動圖請洽詢本公司

1. "☆" the dimensions alter with motor specification.
2. Output shaft diameter:  $\phi 24 \sim \phi 42$  mm.
3. This drawing is model of shell rotation, for shaft rotation drawing, please contact us.

### TTRAD-450E-□-C-D

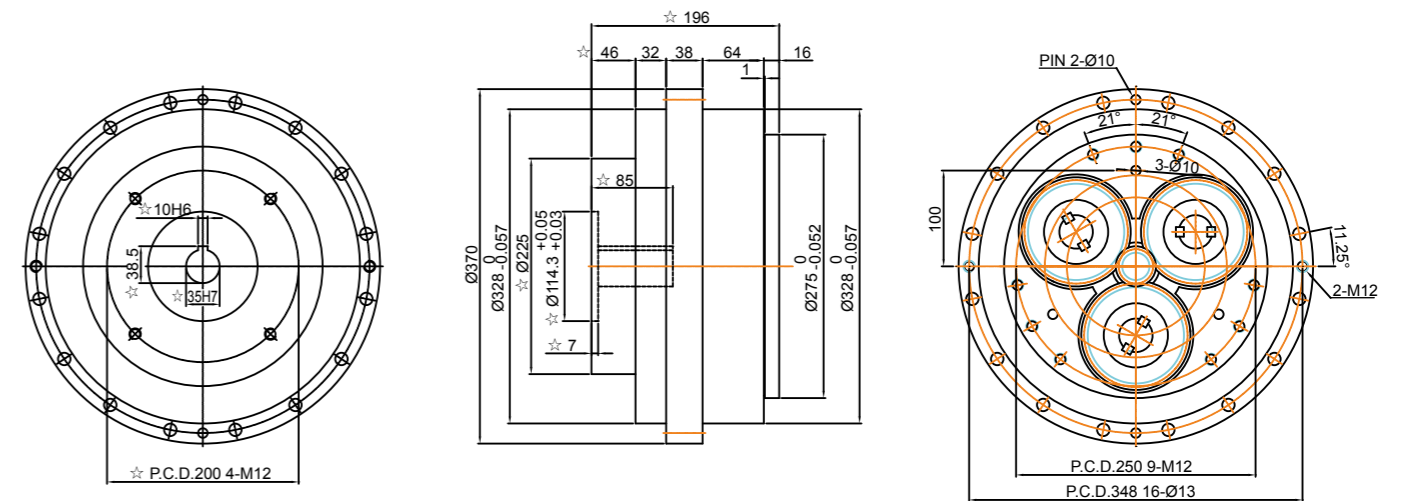

1. ☆ 會隨伺服馬達不同有所變更
2. 本機軸心可從 $\phi 35 \sim \phi 60$
3. 此圖為軸心轉動·殼轉動圖請洽詢本公司

1. "☆" the dimensions alter with motor specification.
2. Output shaft diameter:  $\phi 35 \sim \phi 60$  mm.
3. This drawing is model of shell rotation, for shaft rotation drawing, please contact us.

# TTRV-E 系列

## TTRV-E Series



此系列專為機械手臂開發，而TTRV擁有輕盈的機身，薄型的身長大大的減少機械手臂轉動的慣性使其定位更佳精準

TTRV series is developed for robotic industries. The compact and light weight could reduce the inertia of robot swing to achieve more precise positioning.

- 型式：TTRV-6E ~ TTRV-450E
- 背隙： $\leq 1-3$  弧分
- 減速比：1/78 ~ 1/301
- 轉動方式：軸轉動 or 殼轉動  
(固定出力軸變成殼轉動)
- 額定輸出扭矩：72NM ~ 4410NM

- Type：TTRV-5E ~ TTRV-450E
- Backlash： $\leq 1-3$  Arc.min
- Ratio：1/78 ~ 1/301
- Rotation：Shaft Run or Case Run  
(Fixed output shaft rotation into a shell)
- Rated output torque：72NM ~ 4410NM

# TTRV-E 訂購說明

## TTRV-E Ordering Instructions

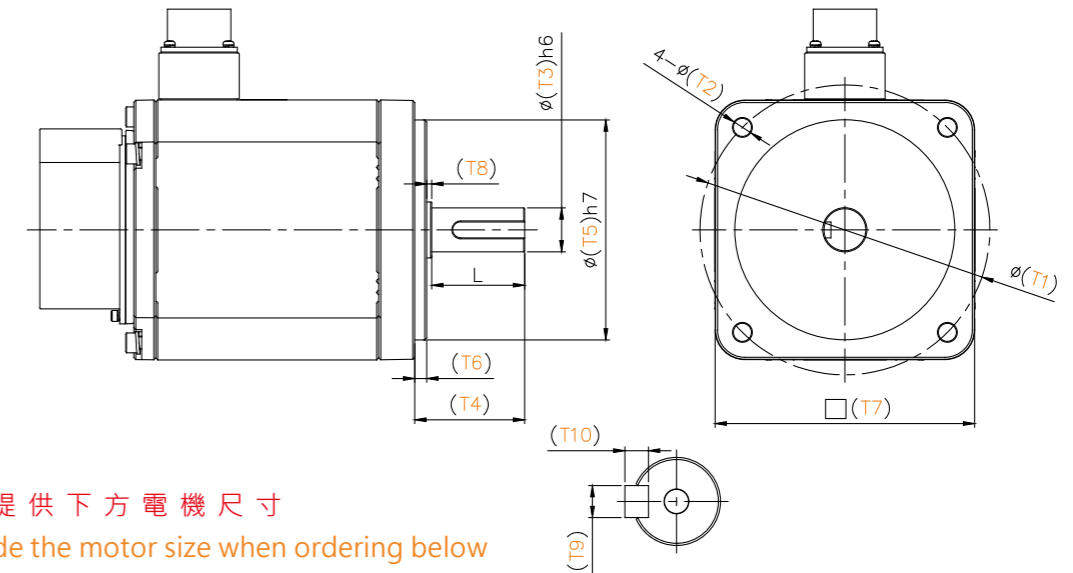

訂購時請提供下方電機尺寸  
Please provide the motor size when ordering below

馬達廠牌 Motor Brand :				
馬達型號 Motor Model :				
T3	T4	T5	T6	T8
馬達軸外徑 Motor Shaft Diameter	馬達軸長度 Motor shaft length	馬達凸緣外徑 Motor Pilot Diameter	馬達緣高度 Motor Pilot Height	非安川免填 Dimeter required when using YASKAWA made motor
L	T9	T10		
馬達軸有效長 Motor Shaht Lenght	鍵寬 Key Width	鍵高 Key Thickness		

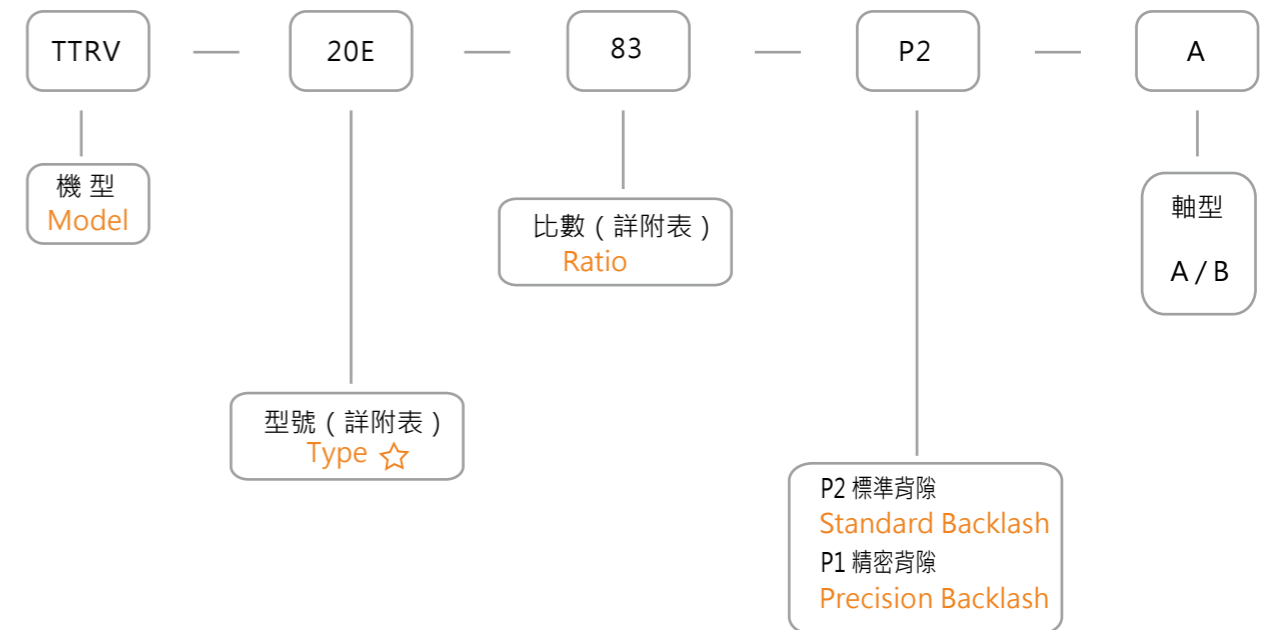

# TTRV-E 性能表

## TTRV-E Technical Specification Table

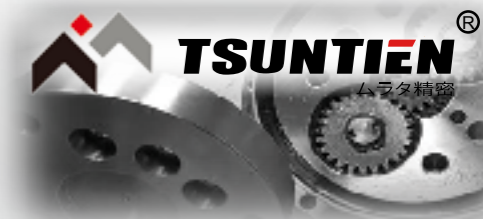

Specification 規格		TTRV-E Technical Specification Table					
Rotation 轉動方式		TTRV-6E		TTRV-20E		TTRV-40E	
		Shaft Run 軸轉動	Case Run 殼轉動	Shaft Run 軸轉動	Case Run 殼轉動	Shaft Run 軸轉動	Case Run 殼轉動
Ratio 減速比		83	82	83	82	83	82
		-	-	103	102	103	102
		-	-	121	120	121	120
		-	-	161	160	161	160
		-	-	-	-	-	-
Rated Output Torque 額定輸出扭矩	NM kgf-m	72 (8.34)		167 (17)		412 (42)	
Acceleration & Braking Torque 加速和制動扭矩	NM kgf-m	117 (12)		412 (42)		1029 (105)	
Instantaneous Max. Allowable Torque 瞬時最大容許轉矩	NM kgf-m	294 (30)		833 (85)		2058 (210)	
Ratrd Input Speed 額定輸入轉速	NR (rpm)	2000		2000		2000	
Ratrd Lifetime 額定壽命	Hr	6000		6000		6000	
Allowable Max. Input Speed 瞬時容許最高輸入轉速	Min (rpm)	3000		3000		2500	
Tilting Stiffness 傾斜鋼度	Nm(arc.min) kgf-m(arc.min)	117 (12)		372 (38)		931 (95)	
Torsional Stiffness 扭轉鋼度	Nm(arc.min) kgf-m(arc.min)	20 (2)		49 (5)		108 (11)	
Max.Lost Motion 最大無效行程	(arc.min)	<2.0		<2.0		<1.5	
Angular Transmission Error 扭轉傳輸中角度偏移量	ATE (arc.sec)	80		40		40	
Backlash 間隙	Standard Backlash 標準背隙	(arc.min)	<3.0	<3.0	<3.0		
	Precision Backlash 精密背隙		<2.0	<2.0	<1.0		
Maximum Tilting Moment 最大傾斜力矩	NM kgf-m	392 (40)		1764 (180)		3332 (340)	
Rated Radial Force 額定徑向力	N/M	196		882		1666	
Max. Axial Force 最大軸向推力	N	1470		3920		5194	
Inertia Of Bending Moment 慣性彎矩 (I=GD <sup>2</sup> /4)	Input Inertial Kg-m <sup>2</sup> 輸入慣量	1.08×10 <sup>-6</sup>		6.01×10 <sup>-6</sup>		2.10×10 <sup>-5</sup>	
		-		4.30×10 <sup>-6</sup>		1.65×10 <sup>-5</sup>	
		-		3.58×10 <sup>-6</sup>		1.38×10 <sup>-5</sup>	
		-		-		0.95×10 <sup>-5</sup>	
Weight 重量	KG	2.8		5		9.5	

PS:需要上述速比之外的減速比時，請洽詢本公司，電機轉速超出額定輸入轉速時，運轉噪音將會提高，請注意減速機容許負載使用表面溫度需低於70°C。

Please contact us for other ratio selections. Please be noted that the noise will be increased when the input speed (RPM:revolution per minute)of motor is higher than rated input speed; the operating temperature and motor service temperature should be under 70°C.

TTRV-E Technical Specification Table												
		TTRV-80E		TTRV-110E		TTRV-160E		TTRV-320E		TTRV-450E		TTRV-700E
		Shaft Run 軸轉動	Case Run 殼轉動	Shaft Run 軸轉動	Case Run 殼轉動	Shaft Run 軸轉動	Case Run 殼轉動	Shaft Run 軸轉動	Case Run 殼轉動	Shaft Run 軸轉動	Case Run 殼轉動	-
		83	82	79	78	109	108	109	108	121	120	
		103	102	109	108	124	123	124	123	181	180	
		121	120	124	123	154	153	181	180	241	240	-
		161	160	154	153	181	180	241	240	301	300	
		-	-	181	180	241	240	301	300	-	-	
		784 (80)		1078 (110)		1568 (160)		3136 (320)		4410 (450)		-
		1960 (200)		2695 (275)		3920 (400)		7840 (800)		11025 (1125)		-
		3920 (400)		5390 (550)		7840 (800)		15680 (1600)		22050 (2250)		-
		2000		2000		2000		1500		1500		-
		6000		6000		6000		6000		6000		-
		2500		2500		2000		2000		2000		-
		1176 (120)		1470 (150)		2940 (300)		4900 (500)		7448 (760)		-
		196 (20)		294 (30)		392 (40)		980 (100)		1176 (120)		-
		<1.0		<1.0		<1.0		<1.0		<1.0		-
		40		40		40		40		40		
		<3.0		<3.0		<3.0		<3.0		<3.0		-
		<1.0		<1.0		<1.0		<1.0		<1.0		
		4312 (440)		5880 (600)		7840 (800)		14112 (1440)		17640 (1800)		-
		2156		2940		3920		7056		8820		-
		7840		10780		14700		19600		24500		
		5.75×10 <sup>-5</sup>		1.03×10 <sup>-4</sup>		1.52×10 <sup>-4</sup>		3.88×10 <sup>-4</sup>		5.70×10 <sup>-4</sup>		
		4.81×10 <sup>-5</sup>		7.02×10 <sup>-4</sup>		1.12×10 <sup>-4</sup>		3.08×10 <sup>-4</sup>		3.32×10 <sup>-4</sup>		
		3.98×10 <sup>-5</sup>		6.85×10 <sup>-4</sup>		0.78×10 <sup>-4</sup>		1.83×10 <sup>-4</sup>		2.35×10 <sup>-4</sup>		-
		2.58×10 <sup>-5</sup>		4.85×10 <sup>-4</sup>		0.70×10 <sup>-4</sup>		1.10×10 <sup>-4</sup>		1.45×10 <sup>-4</sup>		
		-		4.01×10 <sup>-4</sup>		0.48×10 <sup>-4</sup>		0.70×10 <sup>-4</sup>		-		
		16		-		-		28.2		49.6		-



# TTRV-E 尺寸圖

## Drawing & Dimension

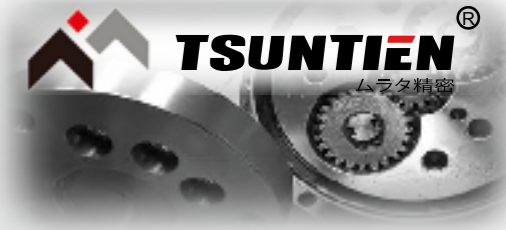

### TTRV-110E

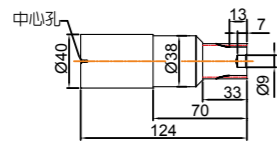
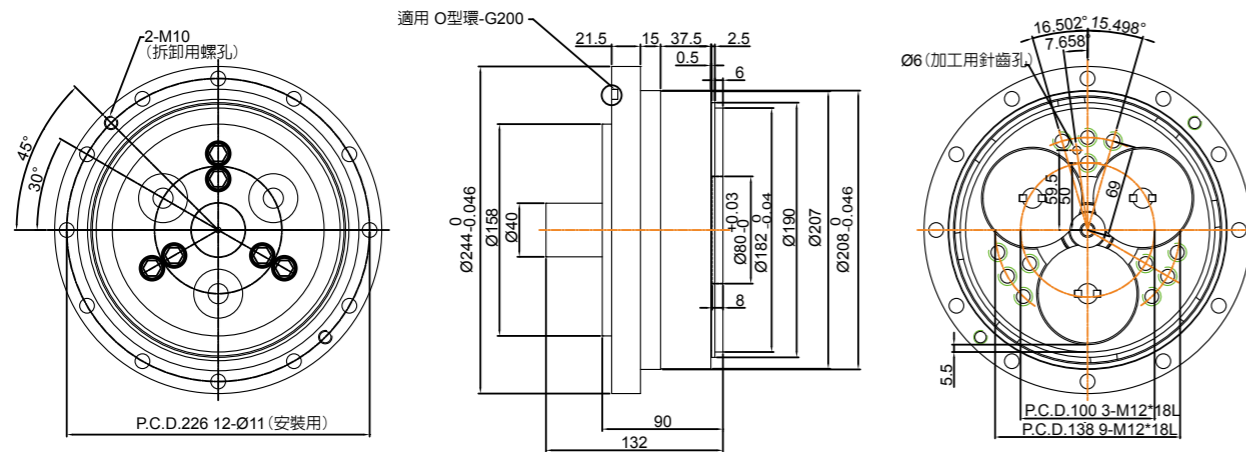

入力軸 尺寸圖

### TTRV-160E

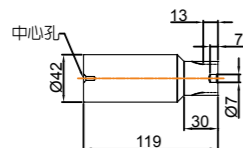
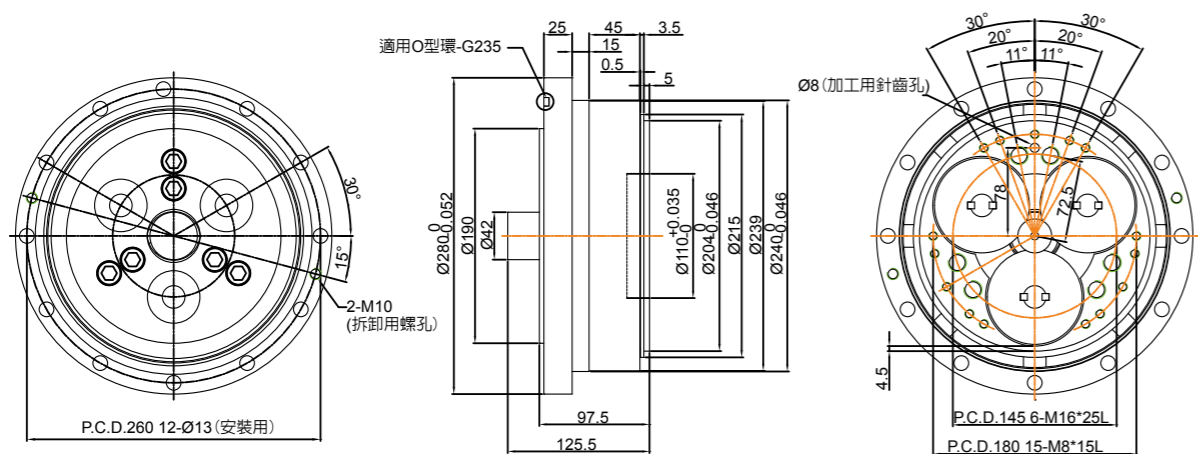

入力軸(A型) 尺寸圖

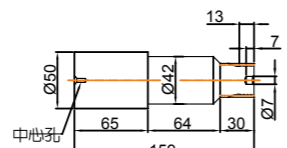

入力軸(B型) 尺寸圖

### TTRV-320E

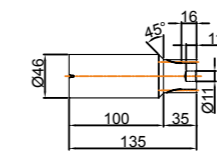
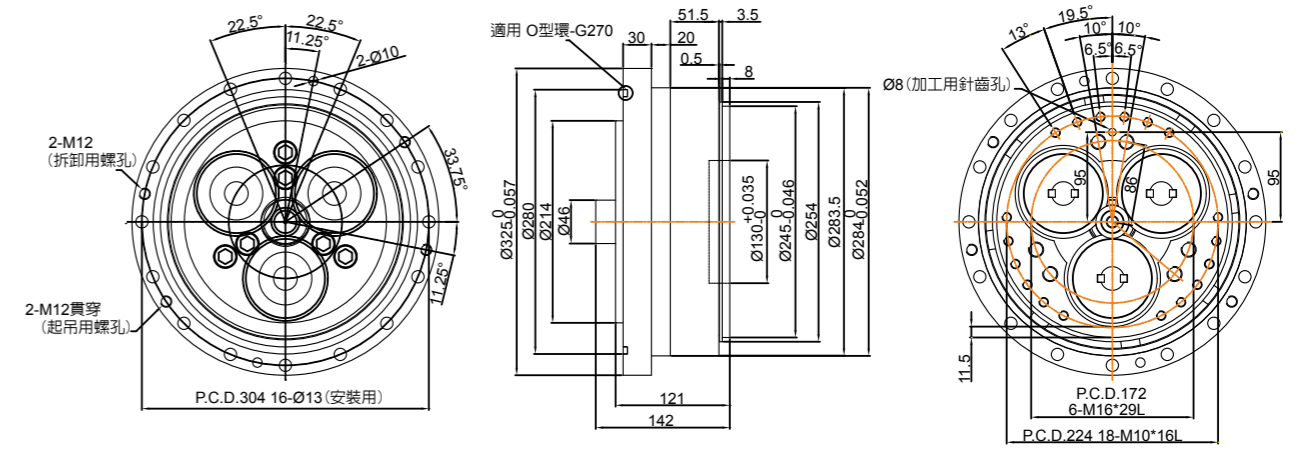

入力軸(A型) 尺寸圖

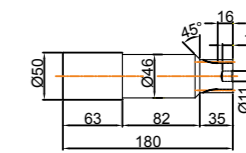

入力軸(B型) 尺寸圖

### TTRV-450E

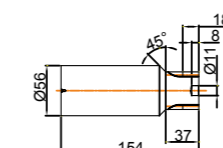
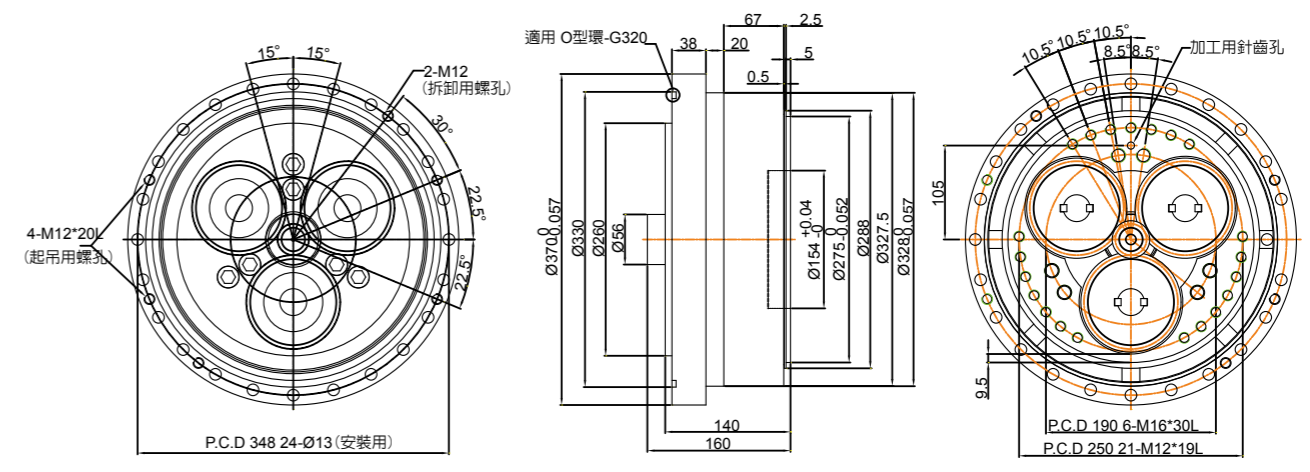

入力軸(A型) 尺寸圖

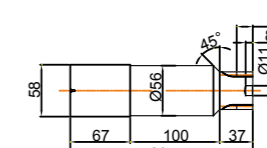

入力軸(B型) 尺寸圖

# TTRV-C 系列

## TTRV-C Series

許多設計師因空間關係，管線無法存放甚至做動時拉扯到管線，這款TTRV-C將可以排除這個困難，因機身為中空可讓管線通過避免了機械做動時的管線拉扯。

Many designers face problem that the cable operation was restrained due to limited space  
The hollow body design of TTRV-C series allows cable to get through without obstruction.



- 型 式：TTRV-10C ~ TTRV-500C
- 背 隙： $\leq 1-5$ 弧分
- 減速比：1/26.625 ~ 1/38.588
- 轉動方式：軸轉動 or 殼轉動
- 額定輸出扭矩：98NM ~ 4900NM

- Type : TTRV-10C ~ TTRV-500C
- Backlash :  $\leq 1-5$  Arc.min
- Ratio : 1/26.625 ~ 1/38.588
- Rotation : Shaft Run or Case Run
- Rated output torque : 98NM ~ 4900NM

## TTRV-C 訂購說明

### TTRV-C Ordering Instructions

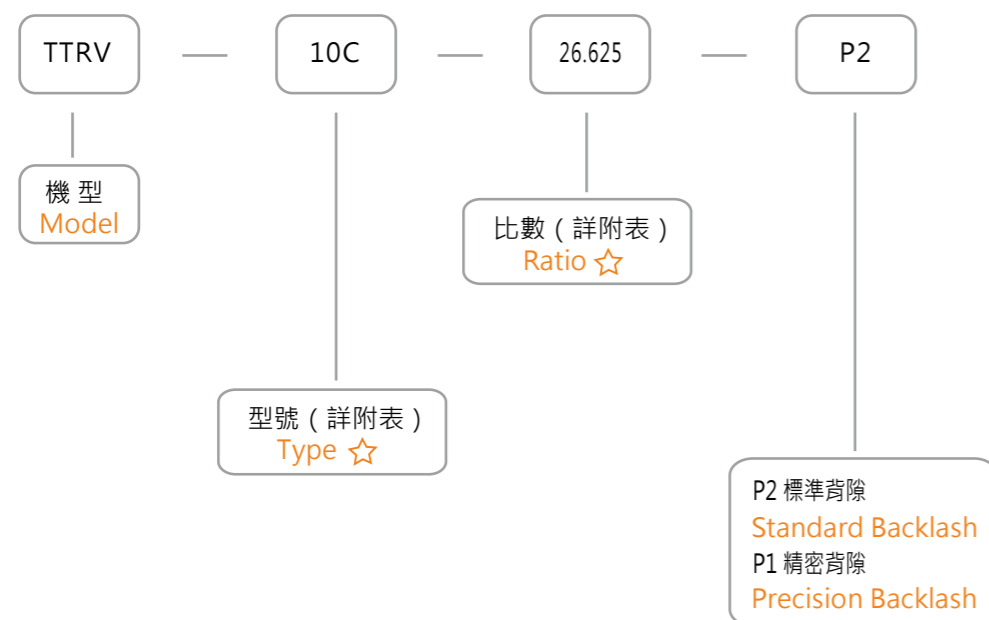

## 外殼轉動型

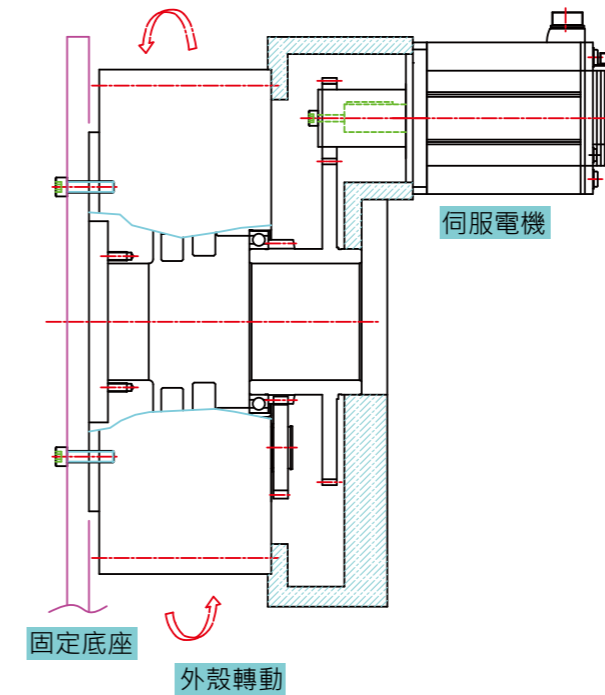

## 心軸轉動型

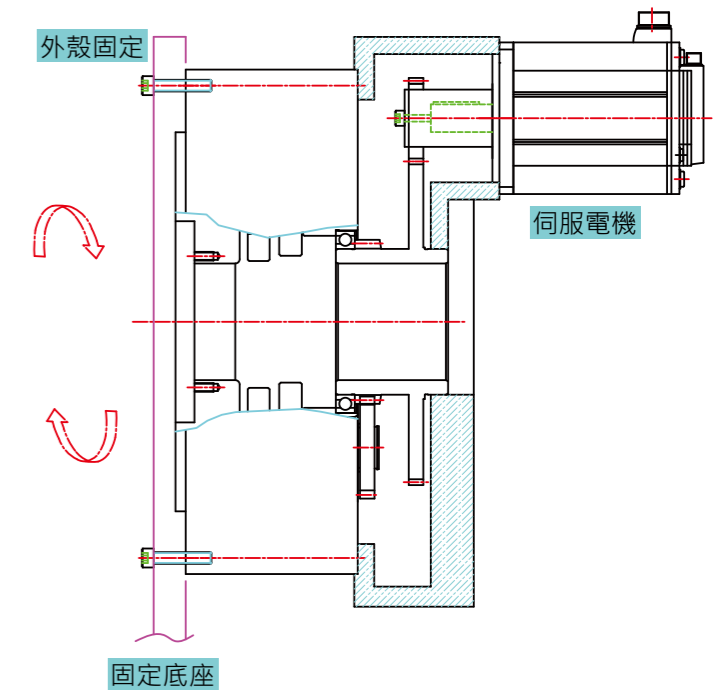

# TTRV-C 性能表

## TTRV-C Technical Specification Table



Specification 規格		TTRV-C Technical Specification Table			TTRV-C Technical Specification Table				
		TTRV-10C	TTRV-30C	TTRV-50C	TTRV-105C	TTRV-200C	TTRV-320C	TTRV-500C	TTRV-700C
Rotation 轉動方式		Shaft Run 軸轉動	Shaft Run 軸轉動	Shaft Run 軸轉動	Shaft Run 軸轉動	Shaft Run 軸轉動	Shaft Run 軸轉動	Shaft Run 軸轉動	-
Ratio 減速比		26.625	34.66	31.6	38.588	35.07	36.5	37	-
Rated Output Torque 額定輸出扭矩	NM kgf-m	98 (10)	295 (30)	490 (50)	1029 (105)	1961 (200)	3136 (325)	4900 (500)	-
Acceleration & Braking Torque 加速和制動扭矩	NM kgf-m	245 (25)	736 (75)	1225 (125)	2570 (262)	4900 (500)	7840 (800)	12250 (1250)	-
Instantaneous Max. Allowable Torque 瞬時最大容許轉矩	NM kgf-m	490 (50)	1472 (150)	2450 (250)	5150 (525)	9800 (1000)	15680 (1600)	24500 (2500)	-
Ratrd Input Speed 額定輸入轉速	NR (rpm)	2000	2000	2000	1500	1500	1500	1500	-
Ratrd Lifetime 額定壽命	Hr	6000	6000	6000	6000	6000	6000	6000	-
Allowable Max. Input Speed 瞬時容許最高輸出轉速	Min (rpm)	3000	3000	3000	2000	2000	2000	2000	-
Tilting Stiffness 傾斜鋼度	Nm(arc.min) kgf-m(arc.min)	421 (43)	1068 (109)	1960 (200)	2813 (287)	9800 (1000)	12740 (1300)	24500 (2500)	-
Torsional Stiffness 扭轉鋼度	Nm(arc.min) kgf-m(arc.min)	47 (4.8)	147 (15)	255 (26)	510 (52)	980 (100)	1960 (200)	3430 (350)	-
Max.Lost Motion 最大無效行程	(arc.min)	<2.0	<2.0	<1.0	<1.0	<1.0	<1.0	<1.0	-
Angular Transmission Error 扭轉傳輸中角度偏移量	ATE (arc.sec)	50	50	50	50	50	50	50	-
Backlash 間隙	Standard Backlash 標準背隙	(arc.min)	<5.0	<3.0	<3.0	<3.0	<3.0	<3.0	-
	Precision Backlash 精密背隙		<3.0	<2.0	<1.0	<1.0	<1.0	<1.0	
Maximum Tilting Moment 最大傾斜力矩	NM kgf-m	1372 (140)	1960 (200)	3528 (360)	4900 (500)	17640 (1800)	39200 (4000)	78400 (8000)	-
Rated Radial Force 額定徑向力	N/M	686	980	1764	2450	8820	20580	34300	-
Max. Axial Force 最大軸向推力	N	5880	8820	11760	13720	19600	29400	39200	-
Inertia Of Bending Moment 慣性彎矩 (I=GD <sup>3</sup> /4)	Input Inertial Kg-m <sup>2</sup> 輸入慣量	1.4×10 <sup>-6</sup>	0.75×10 <sup>-4</sup>	1.9×10 <sup>-4</sup>	0.5×10 <sup>-3</sup>	1.0×10 <sup>-3</sup>	0.7×10 <sup>-2</sup>	1.1×10 <sup>-2</sup>	-
		-	-	-	-	-	-	-	
		-	-	-	-	-	-	-	
		-	-	-	-	-	-	-	
Weight 重量	KG	6		21	27	71			-

PS:需要上述速比之外的減速比時，請洽詢本公司，電機轉速超出額定輸入轉速時，運轉噪音將會提高，請注意減速機容許負載使用表面溫度需低於70°C。

Please contact us for other ratio selections. Please be noted that the noise will be increased when the input speed (RPM:revolution per minute)of motor is higher than rated input speed; the operating temperature and motor service temperature should be under 70°C.

# TTRV-C 尺寸圖

## Drawing & Dimension



### TTRV-10C

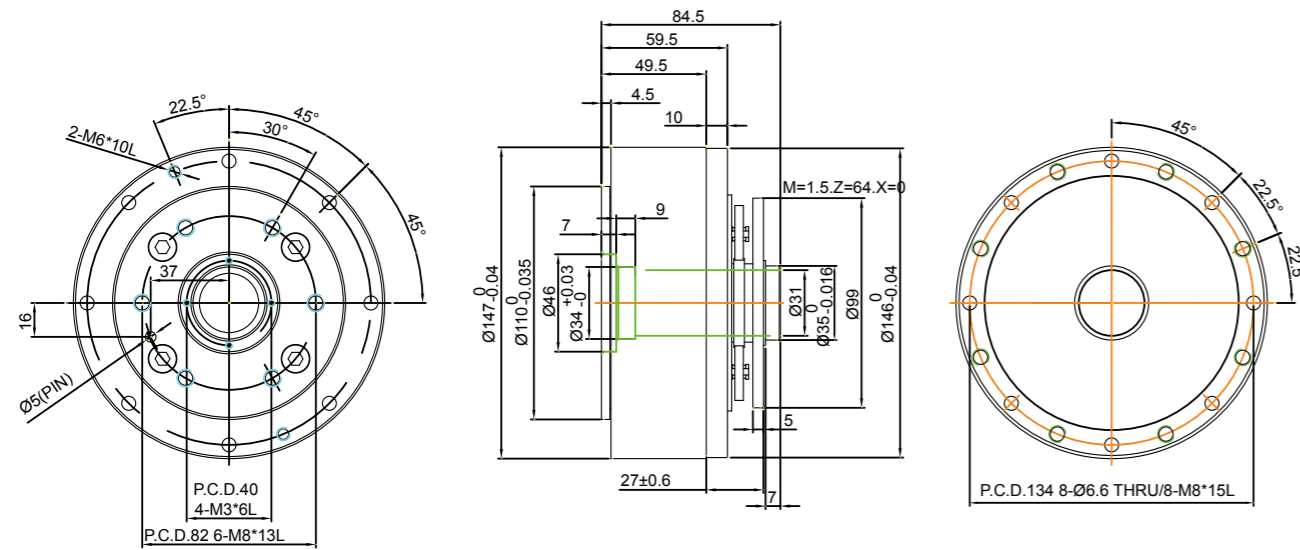

### TTRV-50C

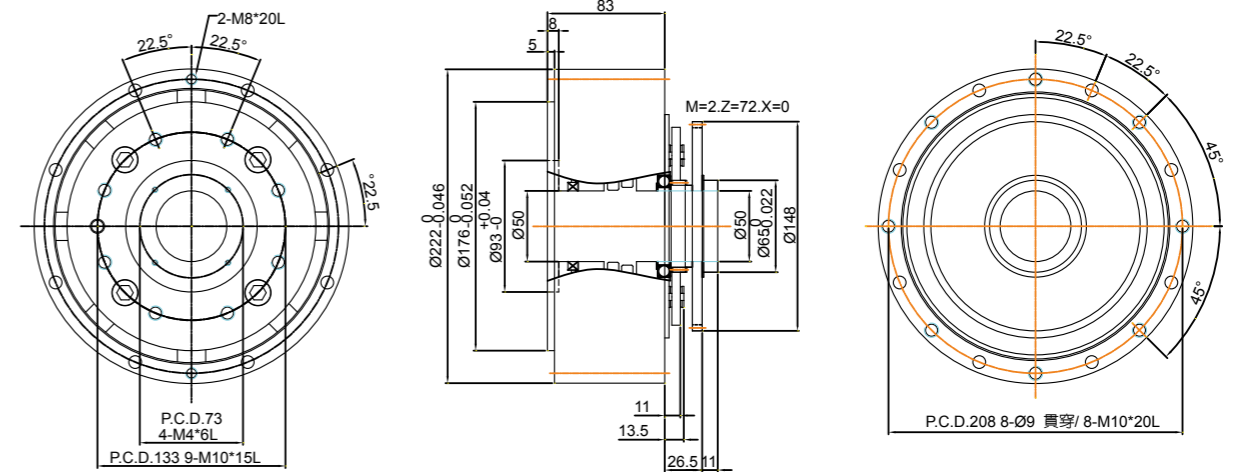

### TTRV-30C

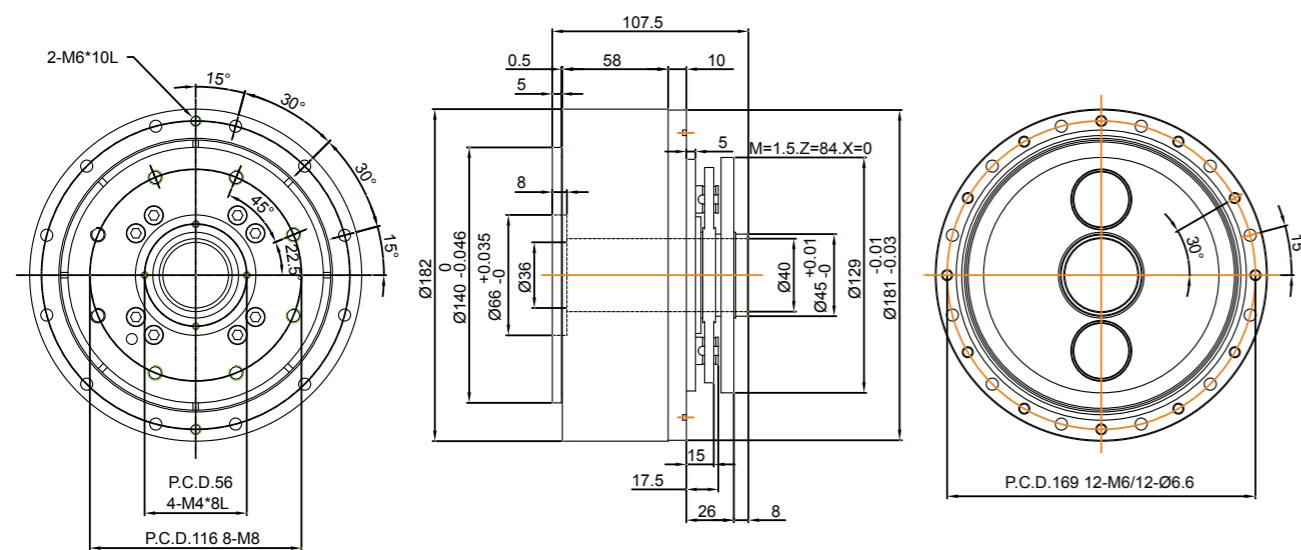

### TTRV-105C

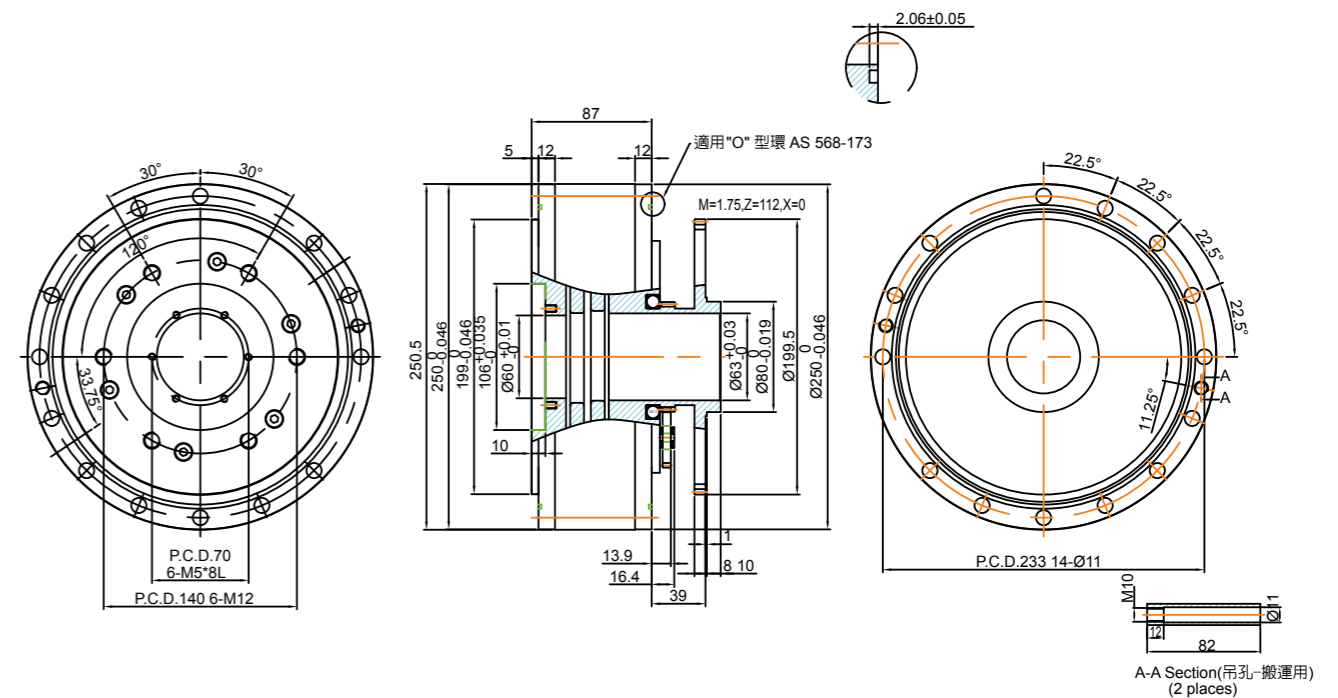

# TTRV-C 尺寸圖

## Drawing & Dimension



### TTRV-200C

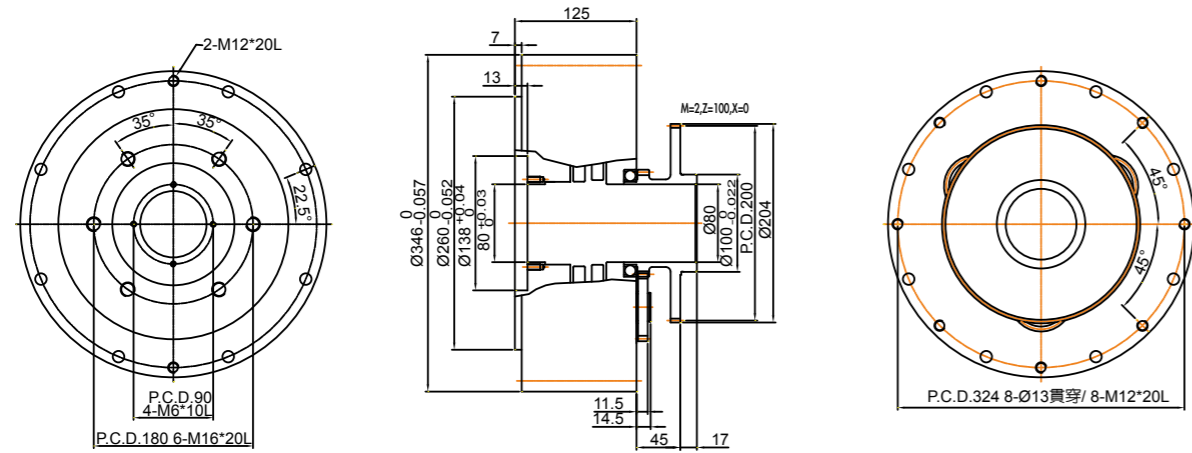

### TTRV-320C

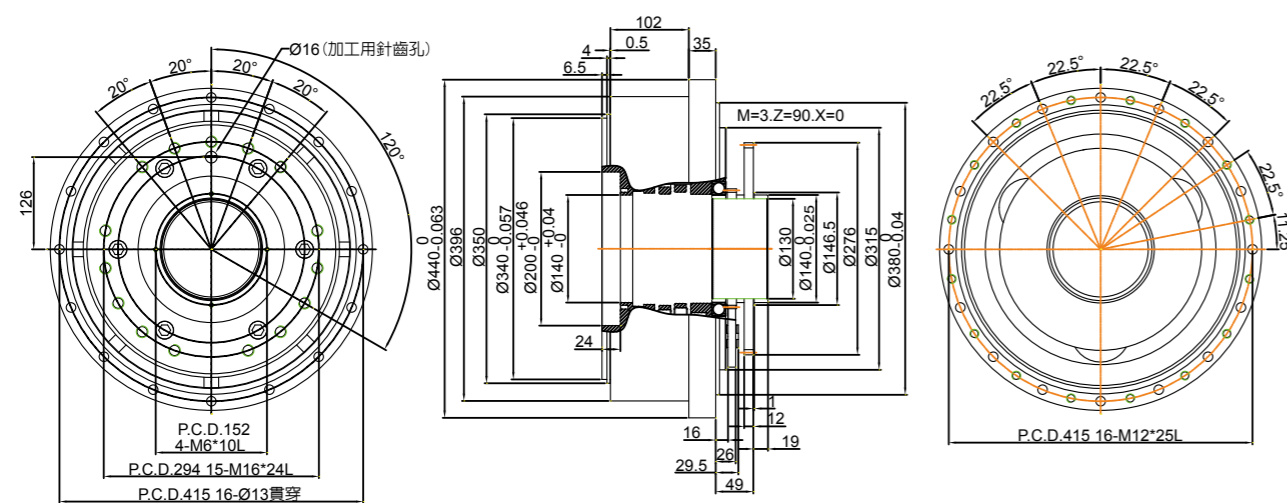

### TTRV-500C

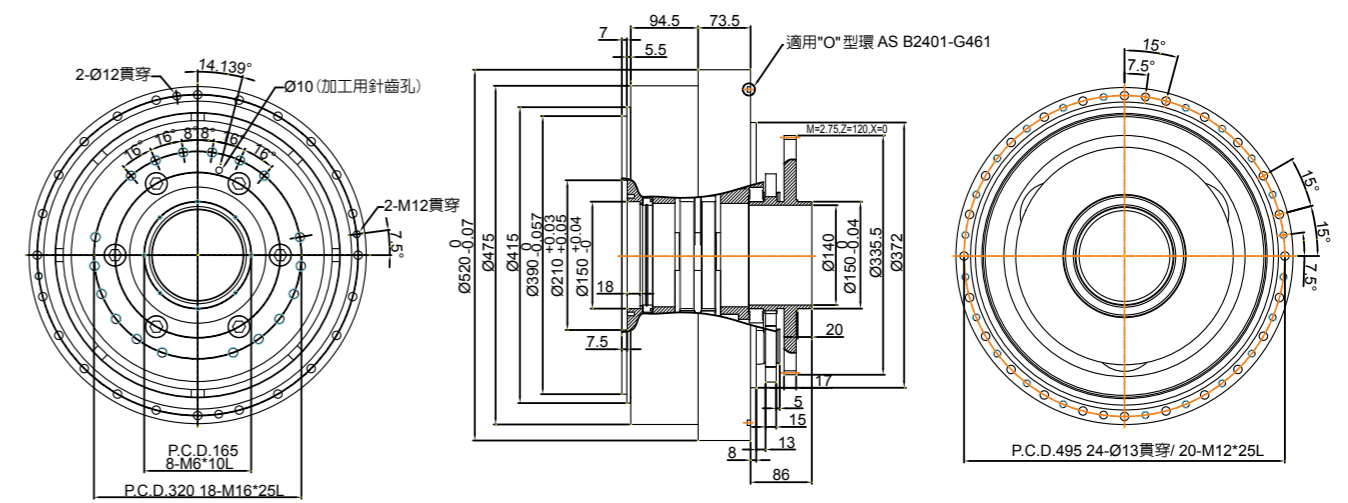

# TTRD-C 系列

## TTRD-C Series



因應市場機械的需要，許多機台以及機械手臂的第一軸必須中空也希望伺服馬達能直結，我們特別開發出TTRD-C來解決這問題，成功的做到減速機中空並且伺服能直結，更能顯現應用的便利性。

To meet with the requirements of mechanism and robot arms with hollow-designed and to be connected to the servo motor directly. TTRD-C series is designed to solve this problem by hollow-body and successfully connected to the servo motor directly, which provide more convenient and application-friendly.

- 型式：TTRD-10C ~ TTRD-500C
  - 背隙：≤1-5弧分
  - 減速比：1/64.38 ~ 1/219
  - 容量：0.2KW ~ 15KW
  - 轉動方式：軸轉動
  - 額定輸出扭矩：98NM ~ 4900NM
- Type：TTRD-10C ~ TTRD-500C
  - Backlash：≤1-5 Arc.min
  - Ratio：1/64.38 ~ 1/219
  - Capacity：0.2KW ~ 15KW
  - Rotation：Shaft Run
  - Rated output torque：98NM ~ 4900NM

# TTRD-C 訂購說明

## TTRD-C Ordering Instructions

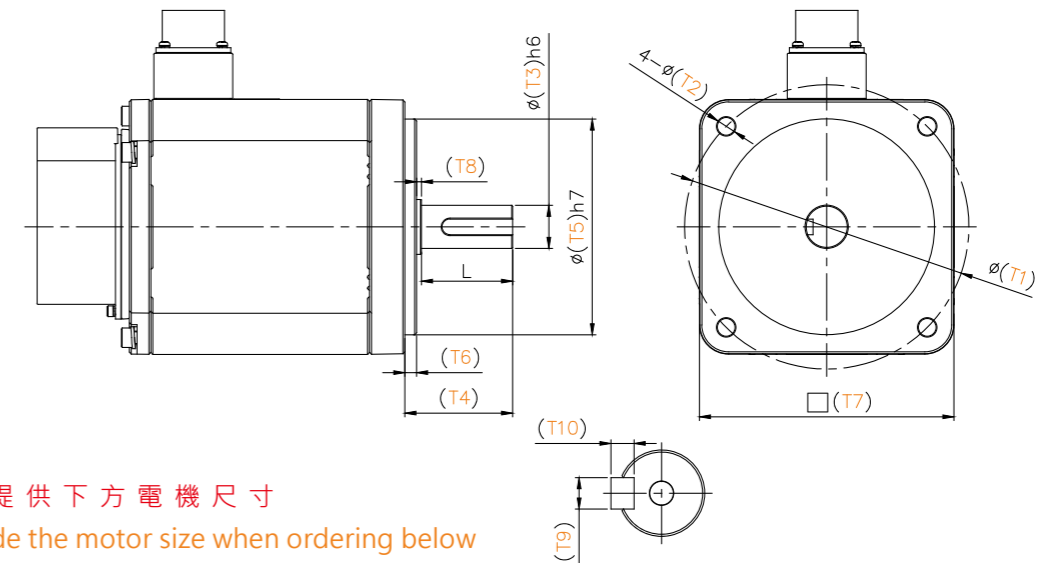
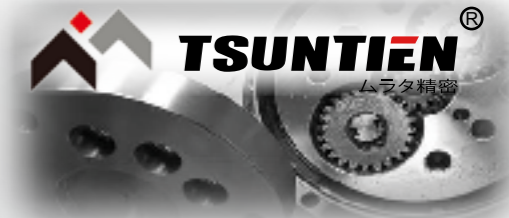

訂購時請提供下方電機尺寸  
Please provide the motor size when ordering below

馬達廠牌 Motor Brand :					
馬達型號 Motor Model :					
T1	T2	T3	T4	T5	T6
螺絲孔中心距 P.C.D	螺絲孔直徑 Bolt Hole Diameter	馬達軸外徑 Motor Shaft Diameter	馬達軸長度 Motor shaft length	馬達凸緣外徑 Motor Pilot Diameter	馬達緣高度 Motor Pilot Height
T7	L	T8	T9	T10	
馬達面尺寸 Motor Flange Cross Section Output	馬達軸有效長 Motor Shaht Lenght	非安川免填 Diameter required when using YASKAWA made motor	鍵寬 Key Width	鍵高 Key Thickness	

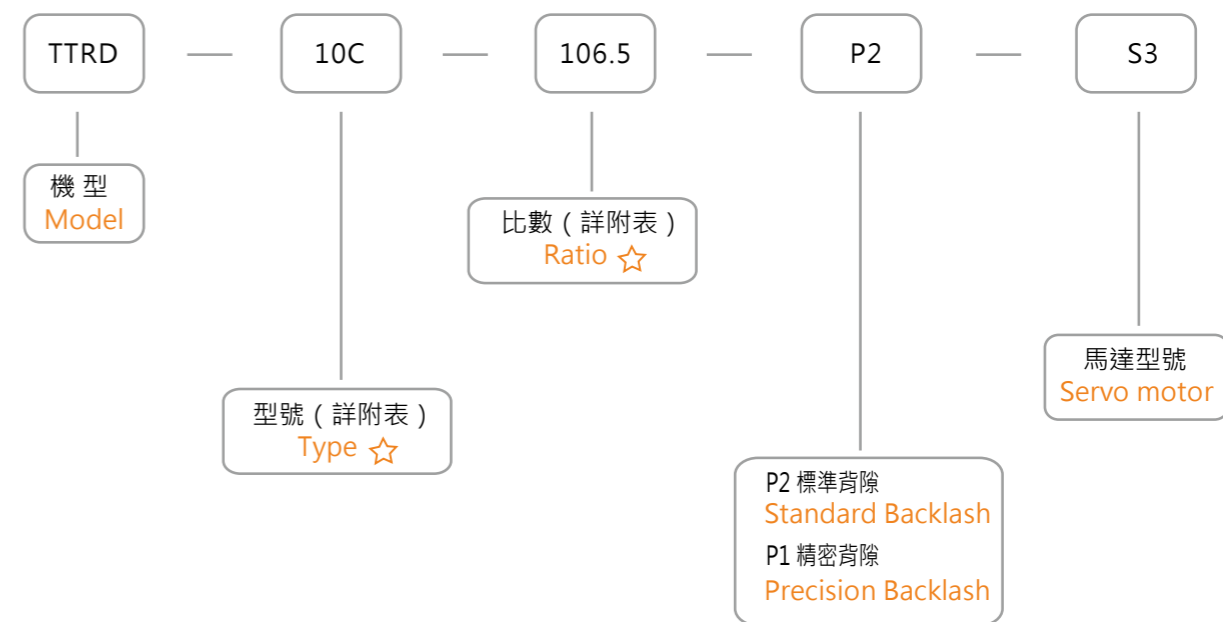

# TTRD-C 性能表

## TTRD-C Technical Specification Table

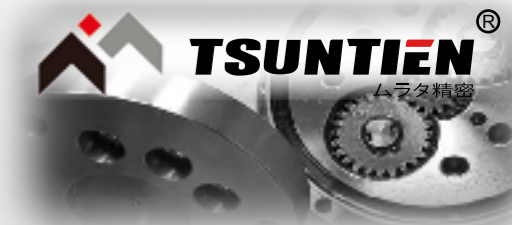

Specification 規格		TTRD-C Technical Specification Table			TTRD-C Technical Specification Table					
		TTRD-10C	TTRD-30C	TTRD-50C	TTRD-105C	TTRD-200C	TTRD-320C	TTRD-500C	TTRD-700C	
<b>Rotation 轉動方式</b>		Shaft Run 軸轉動	Shaft Run 軸轉動	Shaft Run 軸轉動	Shaft Run 軸轉動	Shaft Run 軸轉動	Shaft Run 軸轉動	Shaft Run 軸轉動	-	
Ratio 減速比		106.5	64.38	78.4	97.6777	71.992	94.5	111	-	
		154	84.18	102.4	110.567	92.293	109.5	147		
		-	103.98	126.4	136.347	105.827	123	183		
		-	-	-	187.906	137.9699	153	219		
		-	-	-	-	-	-	-		
Rated Output Torque 額定輸出扭矩	NM kgf-m	98 (10)	295 (30)	490 (50)	1030 (105)	1960 (200)	3136 (325)	4900 (500)	-	
Acceleration & Braking Torque 加速和制動扭矩	NM kgf-m	245 (25)	737 (75)	1225 (125)	2575 (262)	4900 (500)	7840 (800)	12250 (1250)	-	
Instantaneous Max. Allowable Torque 瞬時最大容許轉矩	NM kgf-m	490 (50)	1475 (150)	2450 (250)	5150 (525)	9800 (1000)	15680 (1600)	24500 (2500)	-	
Ratrd Input Speed 額定輸入轉速	NR (rpm)	2000	2000	1500	1500	1500	1500	1500	-	
Ratrd Output Speed 額定輸出轉速	NR (rpm)	15	15	15	15	15	15	15	-	
Ratrd Lifetime 額定壽命	Hr	6000	6000	6000	6000	6000	6000	6000	-	
Maximum Allowable Output Speed(Intermittent) 容許最高輸出轉速 (間歇)	Min (rpm)	28	47	38	26	28	21	18	-	
		19	36	29	23	22	18	14		
		-	29	24	18	19	16	11		
		-	-	-	13	14	13	9		
Allowable Output Speed (Continuous) 容許輸出轉速 (連續)	Min (rpm)	19	31	26	15	21	16	14	-	
		13	24	20	14	16	14	10		
		-	19	16	11	14	12	8		
		-	-	-	8	11	10	7		
Tilting Stiffness 傾斜鋼度	Nm(arc.min) kgf-m(arc.min)	421 (43)	1068 (109)	1960 (200)	2813 (287)	9800 (1000)	12740 (1300)	24500 (2500)	-	
Torsional Stiffness 扭轉鋼度	Nm(arc.min) kgf-m(arc.min)	47 (4.8)	147 (15)	255 (26)	510 (52)	980 (100)	1960 (200)	3430 (350)	-	
Max.Lost Motion 最大無效行程	Lost Motion (arc.sec)	<2.0	<2.0	<1.0	<1.0	<1.0	<1.0	<1.0	-	
Angular Transmission Error 扭轉傳輸中角度偏移量	ATE (arc.sec)	50	50	50	50	50	50	50	-	
Backlash 間隙	Standard Backlash 標準背隙	arcmin	<5.0	<4.0	<3.0	<3.0	<3.0	<3.0	<3.0	-
	Precision Backlash 精密背隙		<3.0	<2.0	<1.0	<1.0	<1.0	<1.0	<1.0	-
Maximum Tilting Moment 最大傾斜力矩	NM kgf-m	1372 (140)	1960 (200)	3528 (360)	4900 (500)	17640 (1800)	39200 (4000)	78400 (8000)	-	
Rated Radial Force 額定徑向力	N/M	686	980	1764	2450	8820	20580	34300	-	
Max.Axial Force 最大軸向推力	N	5880	8820	11760	13720	19600	29400	39200	-	
Start Efficiency 啟動效率	%	65	70	70	80	80	80	80	-	
Weight 重量	KG	10.7	-	34	46	100	176	-	-	

PS:需要上述速比之外的減速比時，請洽詢本公司，電機轉速超出額定輸入轉速時，運轉噪音將會提高，請注意減速機容許負載使用表面溫度需低於70°C。

Please contact us for other ratio selections. Please be noted that the noise will be increased when the input speed (RPM:revolution per minute)of motor is higher than rated input speed; the operating temperature and motor service temperature should be under 70°C.







- 型式：TTRAC-25E ~ TTRAC-325E
- Type : TTRAC-25E ~ TTRAC-325E
- 背隙：≤3-5弧分
- Backlash : ≤3-5 Arc.min
- 減速比：1/35 ~ 1/140
- Ratio : 1/35 ~ 1/140
- 轉動方式：軸轉動 or 殼轉動
- Rotation : Shaft Run or Case Run
- 額定輸出扭矩：245NM ~ 3595NM
- Rated output torque : 245NM ~ 3595NM

### TTRAC-E 訂購說明

### TTRAC-E Ordering Instructions

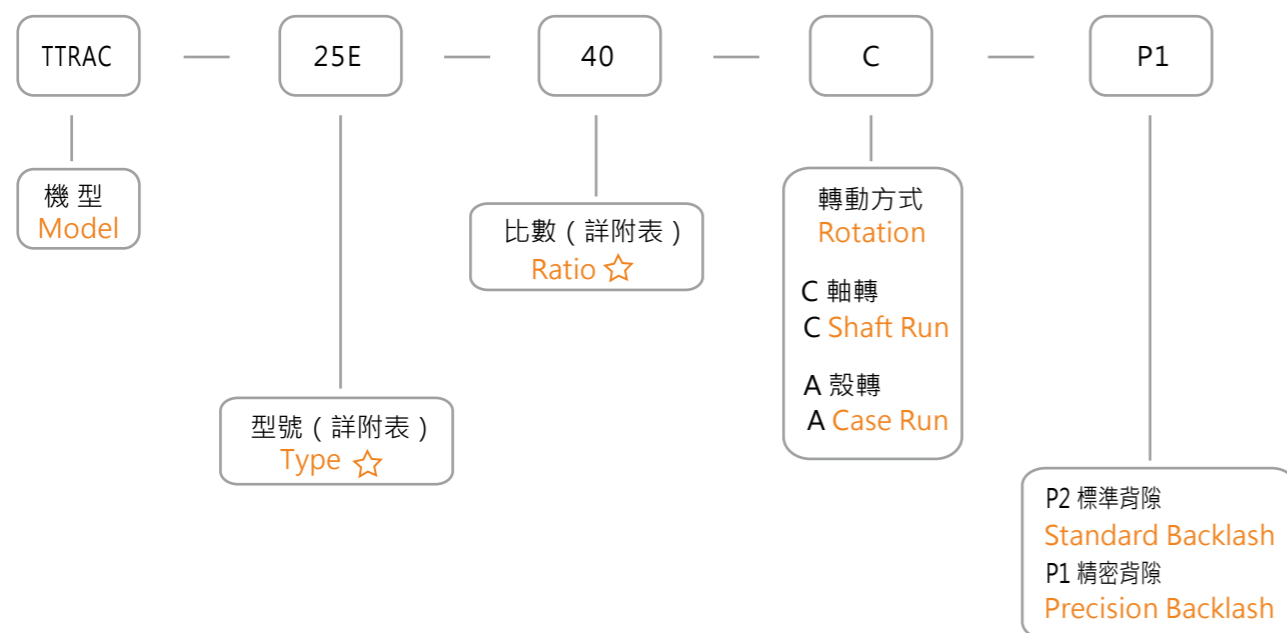

### 外殼轉動型

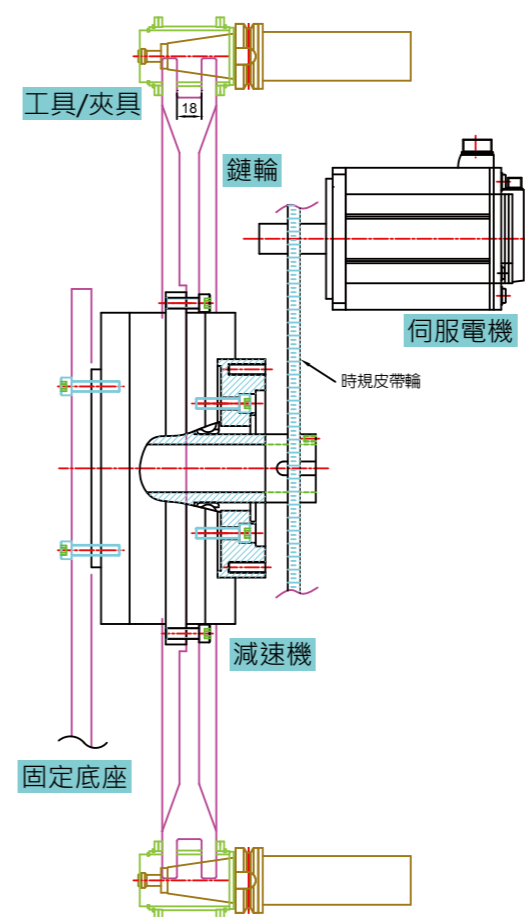

### 心軸轉動型

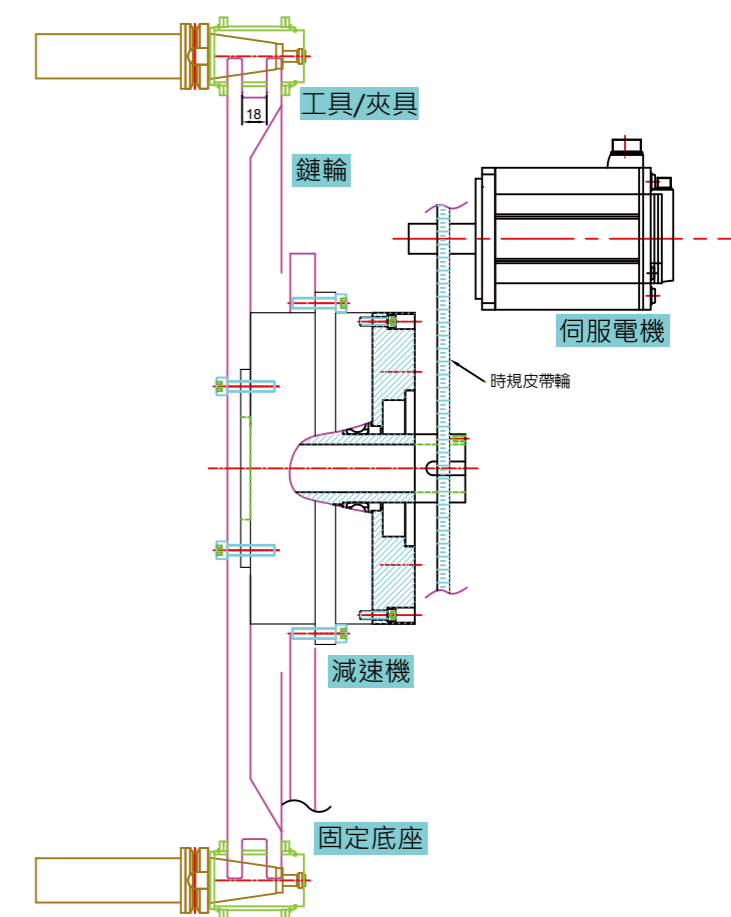

# TTRAC-E 性能表

## TTRAC-E Technical Specification Table

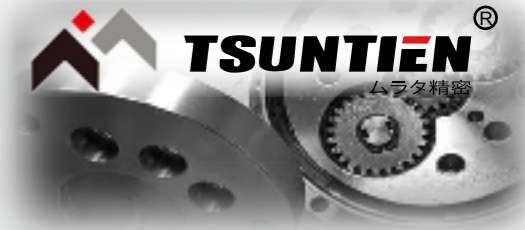

Specification 規格		TTRAC-E Technical Specification Table						TTRAC-E Technical Specification Table							
		TTRAC-25E		TTRAC-45E		TTRAC-135E		TTRAC-165E		TTRAC-325E		TTRAC-450E		TTRAC-700E	
Rotation 轉動方式		Shaft Run 軸轉動	Case Run 殼轉動	Shaft Run 軸轉動	Case Run 殼轉動	Shaft Run 軸轉動	Case Run 殼轉動	Shaft Run 軸轉動	Case Run 殼轉動	Shaft Run 軸轉動	Case Run 殼轉動	-	-	-	-
Ratio 減速比		40	41	35	36	50	51	50	51	59	60	-	-	-	-
		50	51	40	41	60	61	59	60	79	80	-	-	-	-
		59	60	50	51	79	80	79	80	99	100	-	-	-	-
		-	-	59	60	99	100	99	100	119	120	-	-	-	-
		-	-	79	80	-	-	-	-	139	140	-	-	-	-
Rated Output Torque 額定輸出扭矩	NM kgf-m	245 (25)	460 (46.8)	1400 (136)		1615 (165)	3595 (366)	-	-	-	-	-	-	-	-
Acceleration & Braking Torque 加速和制動扭矩	NM kgf-m	515 (52)	1158 (118)	2083 (212)		4043 (412)	7963 (812)	-	-	-	-	-	-	-	-
Instantaneous Max. Allowable Torque 瞬時最大容許轉矩	NM kgf-m	1000 (102)	2300 (234.4)	4155 (423.5)		8075 (823)	17975 (1830)	-	-	-	-	-	-	-	-
Ratrd Input Speed 額定輸入轉速	NR (rpm)	2000	2000	2000		1500	1500	-	-	-	-	-	-	-	-
Ratrd Lifetime 額定壽命	Hr	6000	6000	6000		6000	6000	-	-	-	-	-	-	-	-
Allowable Max. Input Speed 瞬時容許最高輸出轉速	Min (rpm)	3000	3000	2500		2500	2000	-	-	-	-	-	-	-	-
Tilting Stiffness 傾斜鋼度	Nm(arc.min) kgf-m(arc.min)	372 (38)	931 (95)	1176 (120)		2940 (300)	4900 (500)	-	-	-	-	-	-	-	-
Torsional Stiffness 扭轉鋼度	Nm(arc.min) kgf-m(arc.min)	49 (5)	108 (11)	196 (20)		392 (40)	980 (100)	-	-	-	-	-	-	-	-
Max.Lost Motion 最大無效行程	(arc.min)	<2.0	<2.0	<1.5		<1.5	<1.5	-	-	-	-	-	-	-	-
Angular Transmission Error 扭轉傳輸中角度偏移量	ATE (arc.sec)	40	40	40		40	40	-	-	-	-	-	-	-	-
Backlash 間隙	Standard Backlash 標準背隙	(arc.min)	<5.0	<5.0	<5.0		<5.0	<5.0	-	-	-	-	-	-	-
	Precision Backlash 精密背隙		<3.0	<3.0	<3.0		<3.0	<3.0	-	-	-	-	-	-	-
Maximum Tilting Moment 最大傾斜力矩	NM kgf-m	1764 (180)	3332 (340)	4312 (440)		7840 (800)	14112 (1440)	-	-	-	-	-	-	-	-
Rated Radial Force 額定徑向力	N/M	882	1666	2156		3920	7056	-	-	-	-	-	-	-	-
Max. Axial Force 最大軸向推力	N	3920	5194	7840		14700	19600	-	-	-	-	-	-	-	-
Inertia Of Bending Moment 慣性彎矩 (I=GD <sup>3</sup> /4)	Input Inertial Kg-m <sup>2</sup> 輸入慣量	1.08×10 <sup>-5</sup>	4.50×10 <sup>-5</sup>	5.65×10 <sup>-5</sup>		1.9×10 <sup>-4</sup>	6.0×10 <sup>-4</sup>	-	-	-	-	-	-	-	-
		0.65×10 <sup>-5</sup>	3.75×10 <sup>-5</sup>	4.40×10 <sup>-5</sup>		1.8×10 <sup>-4</sup>	5.4×10 <sup>-4</sup>	-	-	-	-	-	-	-	-
		0.45×10 <sup>-5</sup>	2.4×10 <sup>-5</sup>	3.53×10 <sup>-5</sup>		1.78×10 <sup>-4</sup>	4.0×10 <sup>-4</sup>	-	-	-	-	-	-	-	-
		-	1.75×10 <sup>-5</sup>	2.63×10 <sup>-5</sup>		1.51×10 <sup>-4</sup>	2.8×10 <sup>-4</sup>	-	-	-	-	-	-	-	-
		-	1.5×10 <sup>-5</sup>	-		-	1.8×10 <sup>-4</sup>	-	-	-	-	-	-	-	-
Weight 重量	KG	8.3	12	-		-	-	-	-	-	-	-	-	-	-

PS:需要上述速比之外的減速比時，請洽詢本公司，電機轉速超出額定輸入轉速時，運轉噪音將會提高，請注意減速機容許負載使用表面溫度需低於70°C。

Please contact us for other ratio selections. Please be noted that the noise will be increased when the input speed (RPM:revolution per minute)of motor is higher than rated input speed; the operating temperature and motor service temperature should be under 70°C.



# TTRAC-E 尺寸圖

## Drawing & Dimension

### TTRAC-325E-□-C

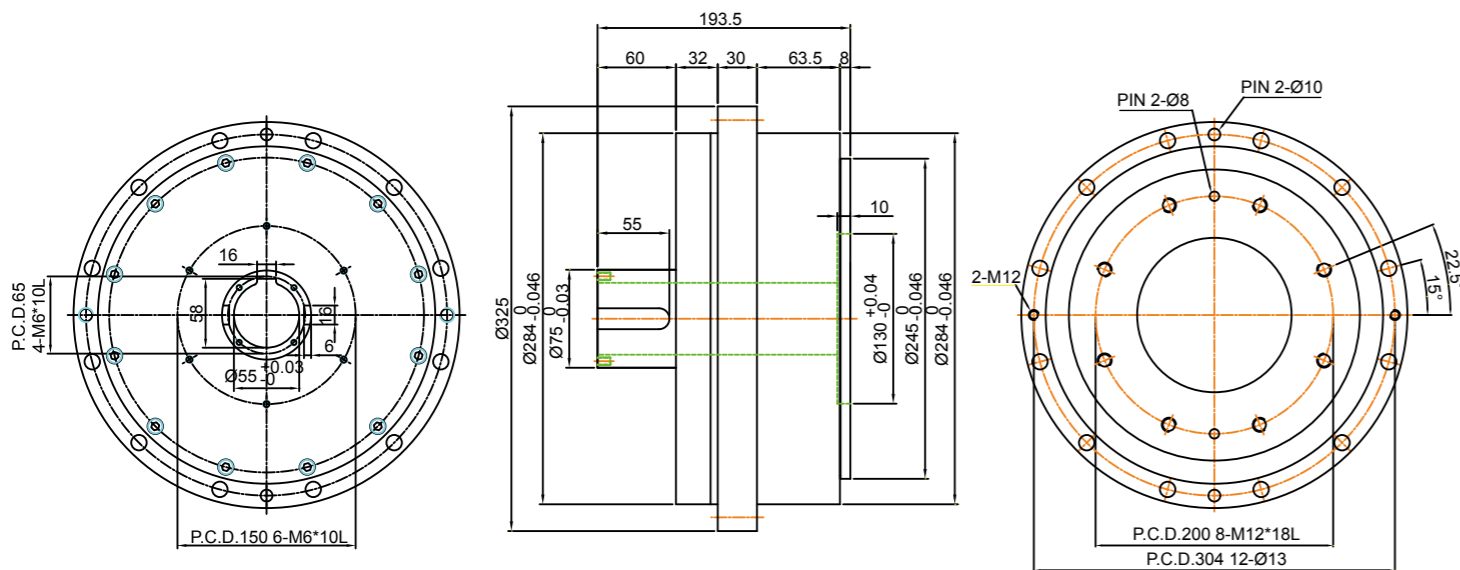

# TTGH 系列

## TTGH Series

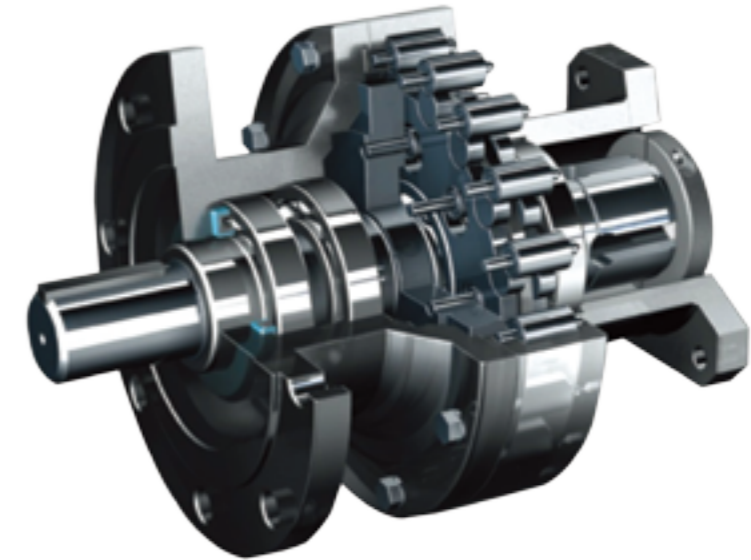

### ROLADRIVE<sup>®</sup> SPEED REDUCER

滾柱傳動減速機

最新型的差速傳動系列

- 背隙微
- 扭力大
- 定位準
- 噪音低
- 效率高
- 壽命長

世界首創-近似共軛元件真圓齒形傳動的先驅

- 滑動微小，效率較高
- 運轉平穩，噪音較低
- 傳動精確，物差較小
- 耗能較省，經濟性佳



# TTGH 訂購說明

## TTGH Ordering Instructions

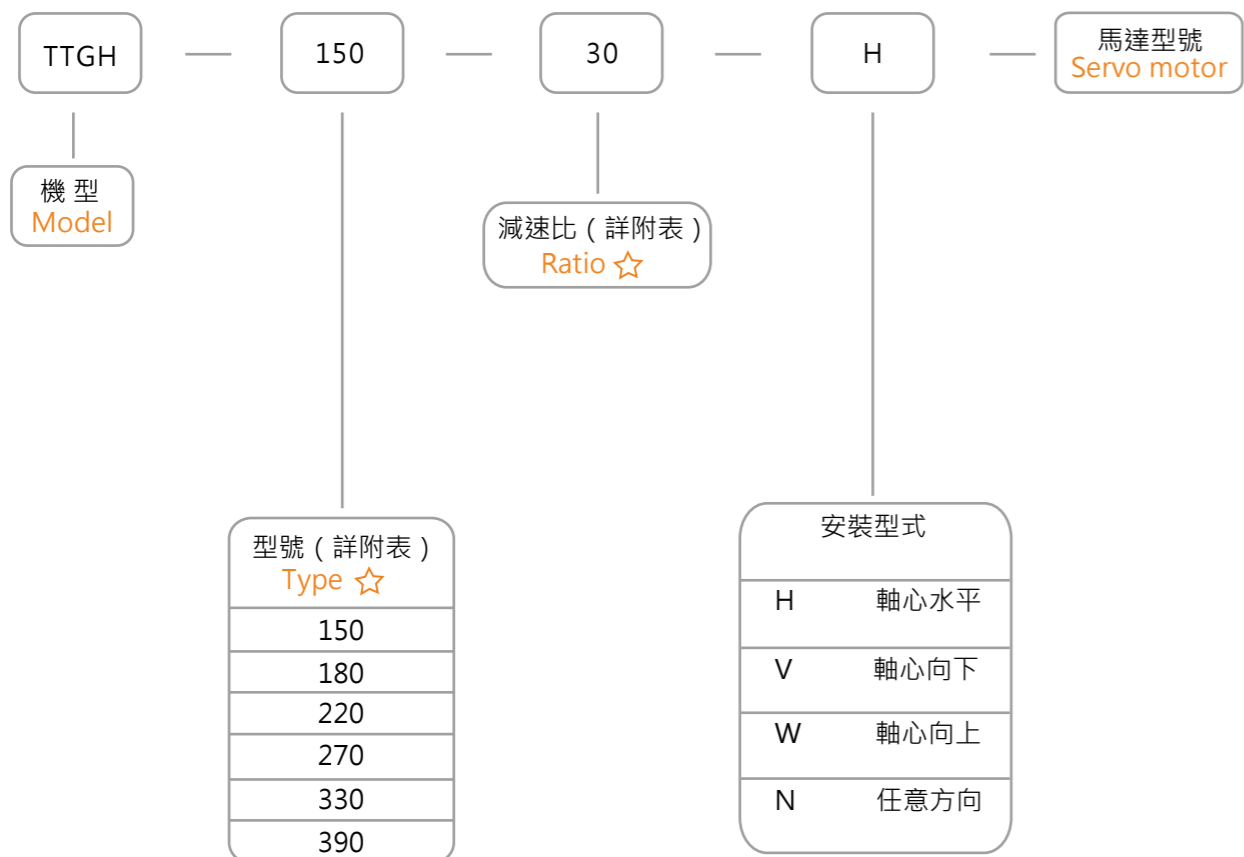

### ● 減速機型式代碼說明



### ● 軸心方向代碼說明

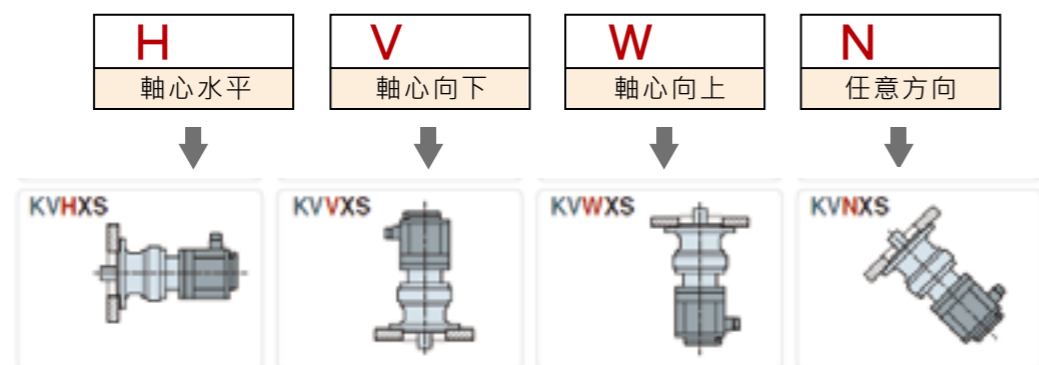

# 滾柱減速機部品名稱 Explosion drawing of speed reducer

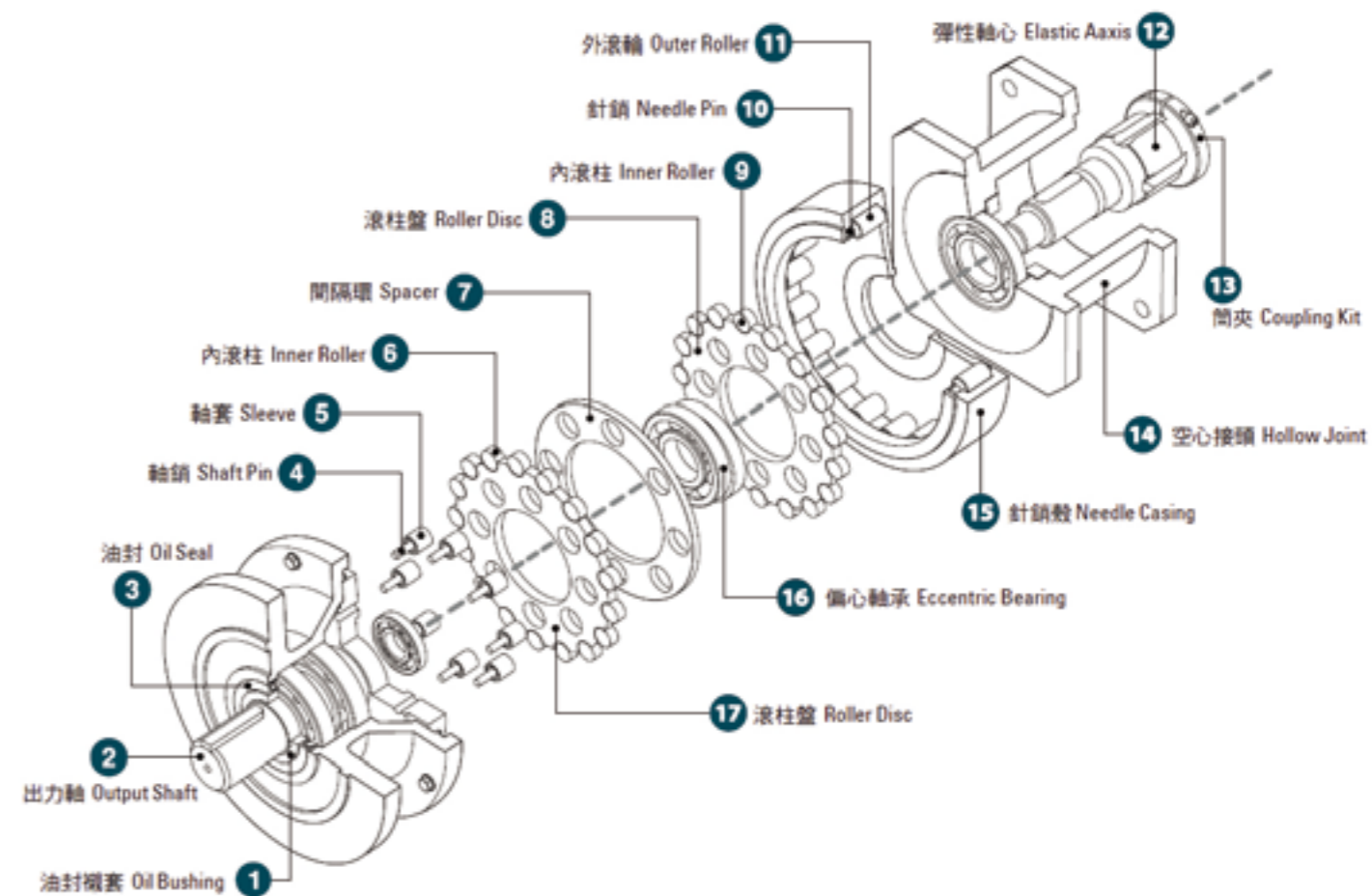
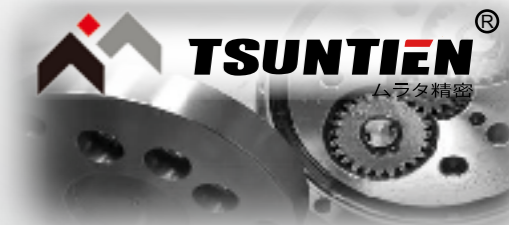

# TTGH尺寸圖

## Drawing & Dimension

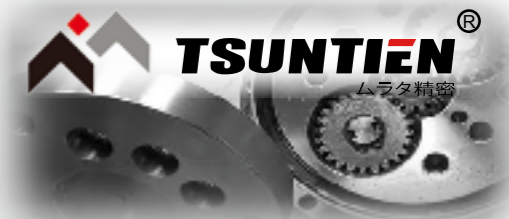

### TTGH-150

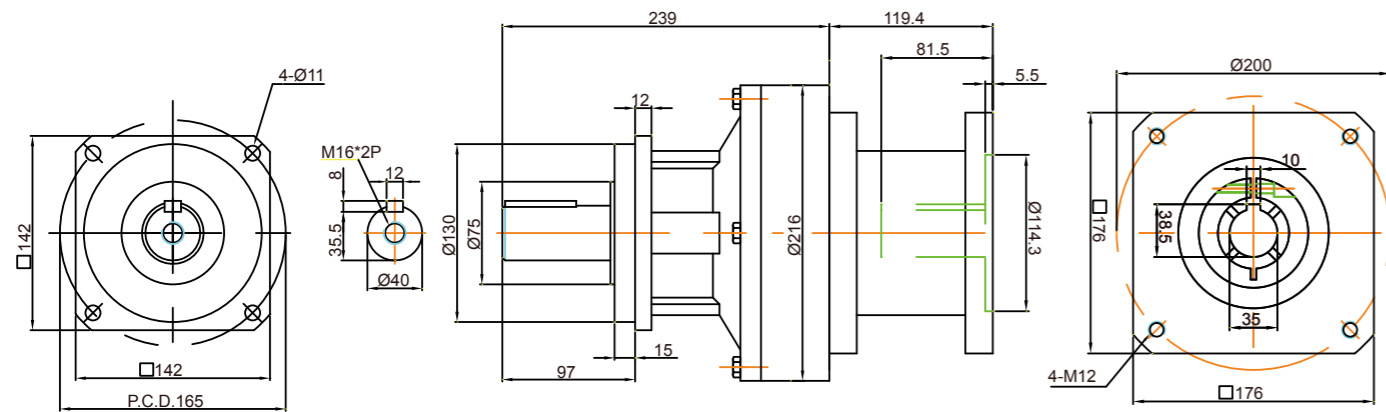

額定輸出 扭矩 Rated output torque	加速和 制動扭矩 Acceleration and braking torque	瞬時最大 允許轉矩 Instantaneous maximum allowable troque	額定輸入 速度 Rated input speed	可允許的 最大輸入 速度 Maximum allowable input speed	間隙 Hysteresis	最大軸向 推力 Max. axial force	啟動效率 Start efficiency	噪音 Noise	減速比 Reduction ratio	重量 Weight
600Nm	1800Nm	3000Nm	3000rpm	5000rpm	<7.0 arcmin	5000N	≥90%	<63db	15/20/25/30/35 40/50/60/70/80 90	33kg

### TTGH-220

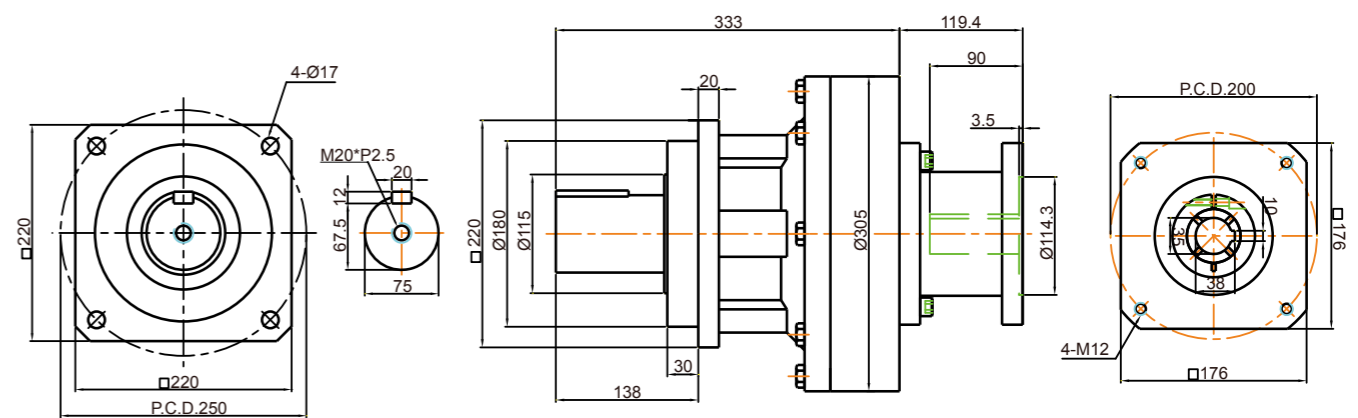

額定輸出 扭矩 Rated output torque	加速和 制動扭矩 Acceleration and braking torque	瞬時最大 允許轉矩 Instantaneous maximum allowable troque	額定輸入 速度 Rated input speed	可允許的 最大輸入 速度 Maximum allowable input speed	間隙 Hysteresis	最大軸向 推力 Max. axial force	啟動效率 Start efficiency	噪音 Noise	減速比 Reduction ratio	重量 Weight
2100Nm	6300Nm	10500Nm	2000rpm	4000rpm	<7.0 arcmin	2500N	≥90%	<65db	15/20/25/30/35 40/50/60/70/80 90/100/120	80kg

### TTGH-180

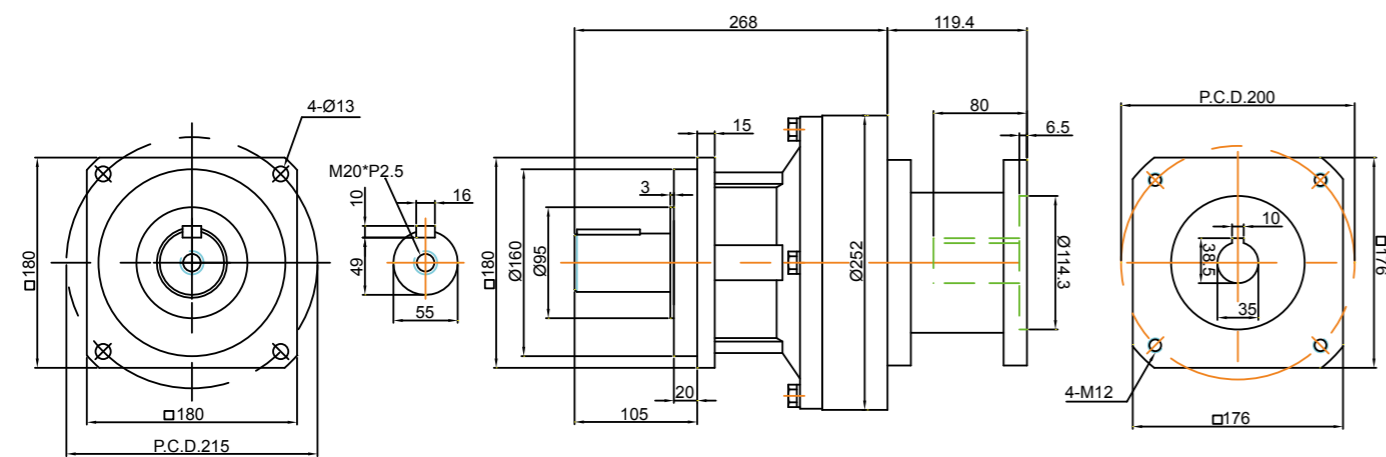

額定輸出 扭矩 Rated output torque	加速和 制動扭矩 Acceleration and braking torque	瞬時最大 允許轉矩 Instantaneous maximum allowable troque	額定輸入 速度 Rated input speed	可允許的 最大輸入 速度 Maximum allowable input speed	間隙 Hysteresis	最大軸向 推力 Max. axial force	啟動效率 Start efficiency	噪音 Noise	減速比 Reduction ratio	重量 Weight
120Nm	3600Nm	6000Nm	3000rpm	5000rpm	<7.0 arcmin	7500N	≥90%	<65db	15/20/25/30/35 40/50/60/70/80 90/100	43kg

### TTGH-270

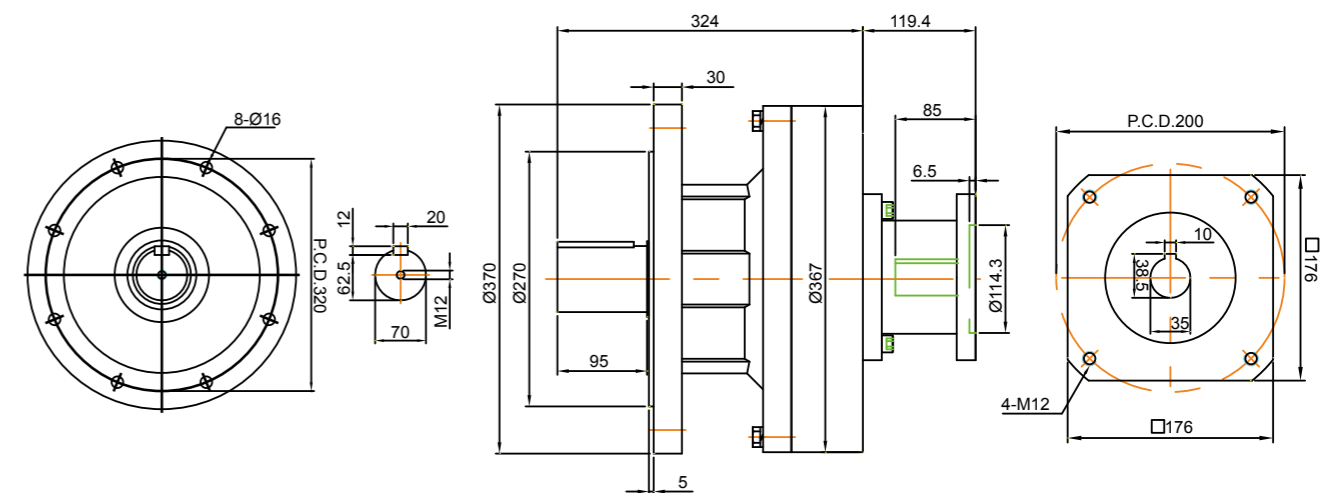

額定輸出 扭矩 Rated output torque	加速和 制動扭矩 Acceleration and braking torque	瞬時最大 允許轉矩 Instantaneous maximum allowable troque	額定輸入 速度 Rated input speed	可允許的 最大輸入 速度 Maximum allowable input speed	間隙 Hysteresis	最大軸向 推力 Max. axial force	啟動效率 Start efficiency	噪音 Noise	減速比 Reduction ratio	重量 Weight
5000Nm	15000Nm	25000Nm	1500rpm	2000rpm	<7.0 arcmin	7500N	≥90%	<70db	15/20/25/30/35 40/50/60/70/80 90/100	136kg

# TTGH尺寸圖

## Drawing & Dimension

### TTGH-330

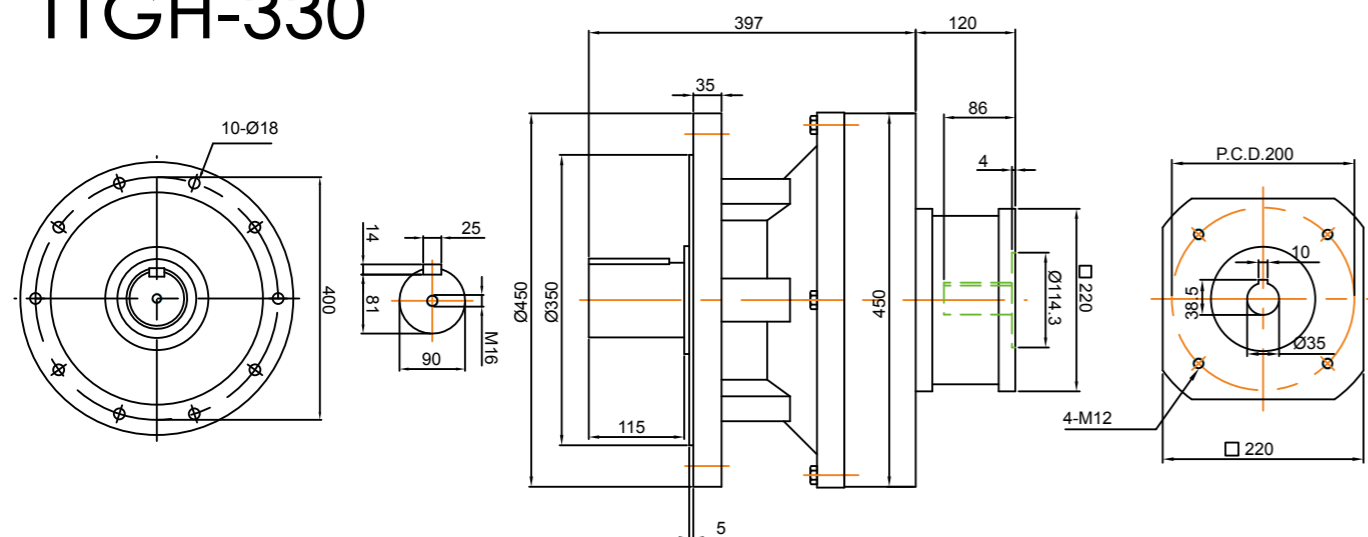

額定輸出 扭矩 Rated output torque	加速和 制動扭矩 Acceleration and braking torque	瞬時最大 允許轉矩 Instantaneous maximum allowable torque	額定輸入 速度 Rated input speed	可允許的 最大輸入 速度 Maximum allowable input speed	間隙 Hysteresis	最大軸向 推力 Max. axial force	啟動效率 Start efficiency	噪音 Noise	減速比 Reduction ratio	重量 Weight
9500Nm	28500Nm	47500Nm	1500rpm	2000rpm	<8.0 arcmin	8200N	≥90%	<70db	15/20/25/30/35 40/50/60/70/80 90/100/120	225kg

### TTGH-390

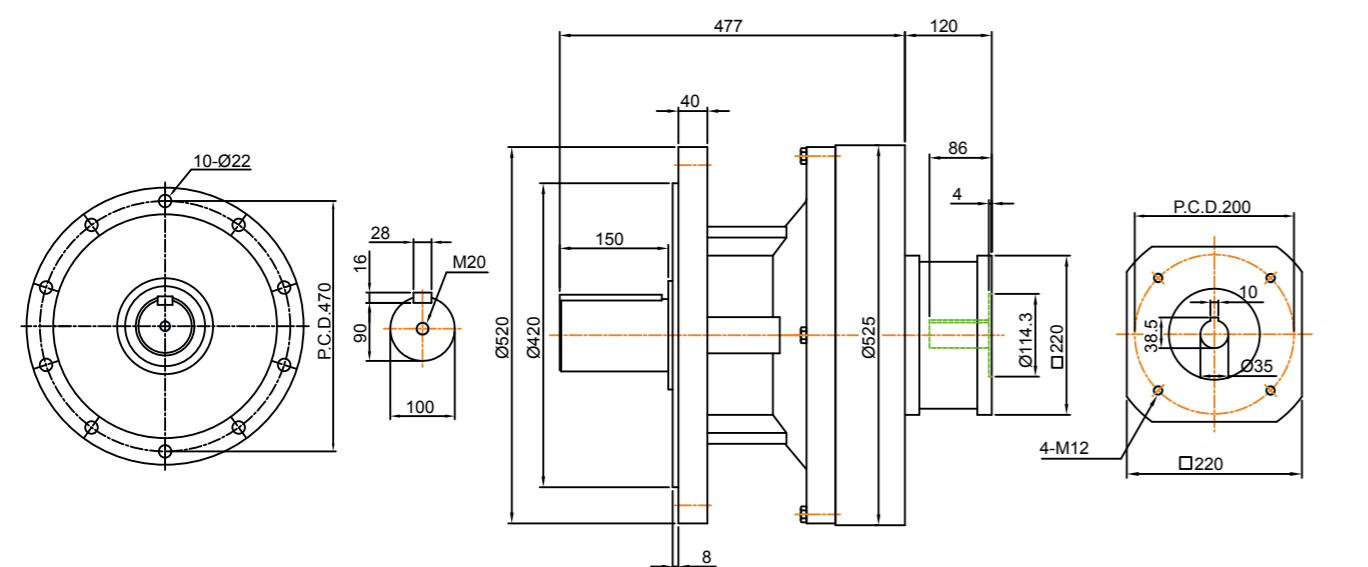

額定輸出 扭矩 Rated output torque	加速和 制動扭矩 Acceleration and braking torque	瞬時最大 允許轉矩 Instantaneous maximum allowable troque	額定輸入 速度 Rated input speed	可允許的 最大輸入 速度 Maximum allowable input speed	間隙 Hysteresis	最大軸向 推力 Max. axial force	啟動效率 Start efficiency	噪音 Noise	減速比 Reduction ratio	重量 Weight
15000Nm	45000Nm	75000Nm	1000rpm	1500rpm	<10.0 arcmin	12000N	≥85%	<70db	15/20/25/30/35 40/50/60/70/80 90/100	350kg

# 設計注意事項 裝配精度需求

## Key Points Of Choice

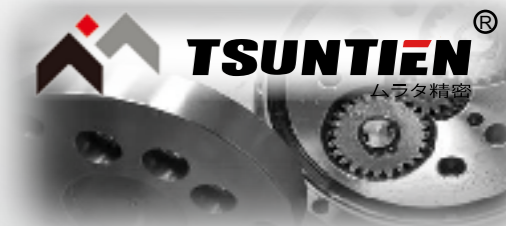

伺服電機安裝法蘭請依照以下精度安裝，避免產生震動以及噪音

型式	同心度公差	平行度公差	中心距公差
TTRV-6E	MAX±0.03	MAX±0.03	
TTRV-20E	MAX±0.03	MAX±0.03	
TTRV-40E	MAX±0.03	MAX±0.03	
TTRV-80E	MAX±0.03	MAX±0.03	
TTRV-110E	MAX±0.03	MAX±0.03	
TTRV-160E	MAX±0.05	MAX±0.03	
TTRV-320E	MAX±0.05	MAX±0.03	
TTRV-450E	MAX±0.05	MAX±0.03	
TTRA-5E	MAX±0.03	MAX±0.03	
TTRA-7E	MAX±0.03	MAX±0.03	
TTRA(RAC)-25E	MAX±0.03	MAX±0.03	
TTRA(RAC)-45E	MAX±0.03	MAX±0.03	
TTRA(RAC)-135E	MAX±0.03	MAX±0.03	
TTRA(RAC)-165E	MAX±0.05	MAX±0.03	
TTRA(RAC)-325E	MAX±0.05	MAX±0.03	
TTRA-450E	MAX±0.05	MAX±0.03	
TTRAD-7E	MAX±0.03	MAX±0.03	
TTRAD-25E	MAX±0.03	MAX±0.03	
TTRAD-45E	MAX±0.03	MAX±0.03	
TTRAD-135E	MAX±0.03	MAX±0.03	
TTRAD-165E	MAX±0.05	MAX±0.03	
TTRAD-325E	MAX±0.05	MAX±0.03	
TTRAD-450E	MAX±0.05	MAX±0.03	
TTRV(RD)-10C	MAX±0.03	MAX±0.03	MAX±0.03
TTRV(RD)-30C	MAX±0.03	MAX±0.03	MAX±0.03
TTRV(RD)-50C	MAX±0.03	MAX±0.03	MAX±0.03
TTRV(RD)-105C	MAX±0.03	MAX±0.03	MAX±0.03
TTRV(RD)-200C	MAX±0.03	MAX±0.03	MAX±0.03
TTRV(RD)-320C	MAX±0.03	MAX±0.03	MAX±0.03
TTRV(RD)-500C	MAX±0.03	MAX±0.05	MAX±0.03

# 選用注意事項

## Procedure Of Selecting Reducer

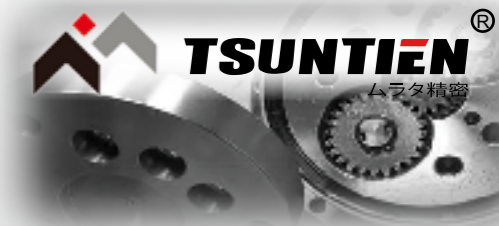

$$T_m = \sqrt[10]{\frac{t_1 \cdot N_1 \cdot T_1^{\frac{10}{3}} + t_2 \cdot N_2 \cdot T_2^{\frac{10}{3}} + \dots + t_n \cdot N_n \cdot T_n^{\frac{10}{3}}}{t_1 \cdot N_1 + t_2 \cdot N_2 + \dots + t_n \cdot N_n}}$$

已知平均負載轉矩  $T_m$   
(average load torque)  
已知平均輸出轉速  $N_m$   
(average output speed)  
<請參閱伺服馬達規格>

對照額定表  
(comparing nominal chart)

輸出轉矩  $T_m$   
(output torque)

輸出轉速  $N_m$   
(output speed)

$$N_m = \frac{t_1 \cdot N_1 + t_2 \cdot N_2 + \dots + t_n \cdot N_n}{t_1 + t_2 + \dots + t_n}$$

$MC \leq$  允許彎矩  
 $MC \leq$  allowable bending torque

$$MC = (W_1 \cdot l_2 + W_2 \cdot l_3 (l_2 > b)) / 1000$$

確定負載彎矩  $MC$   
ensure tilt load torque  $MC$

$MC >$  允許彎矩  
 $MC >$  allowable bending torque

$\theta \leq$  允許傾斜  
 $\theta \leq$  allowable tilt

$$\theta = (W_1 \cdot l_1 + W_2 \cdot l_3) / (M_t \times 10^3)$$

確定彎矩剛性  $\theta$   
ensure bending rigidity  $\theta$

$\theta >$  允許傾斜  
 $\theta >$  allowable tilt

確定主軸承能力  
(ensure main bearing capability)

$T_{out} >$  允許瞬時最大轉矩  
 $T_{out} >$  allowable torque for instantaneity

$T_{out} \leq$  允許瞬時最大轉矩  
 $T_{out} \leq$  allowable torque for instantaneity

電機軸 0 旋轉時  
外部衝擊轉矩  $T_{out}$   
External impact torque, during stall status of motor

$$T_{out} = T_{m1} \times R \times \eta$$

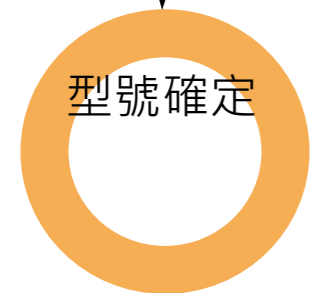

目前預定型號 (可提高機型減少負載)  
trial model (suggest: enlarged model to reduce load)

$$L_h = k \cdot \frac{N_o}{N_m} \cdot \left( \frac{T_o}{T_m} \right)^{\frac{10}{3}}$$

計算機型壽命  $L_h$   
reducer life calculation  $L_h$

$L_h <$  數值  
 $L_h <$  data

$L_h \geq$  數值  
 $L_h \geq$  data

輸入轉速  $\leq$  允許最高轉速  
減速比  $\leq$  允許最高轉速  
 $\frac{\text{input speed}}{\text{reduction ratio}} \leq \text{allowable maximum speed}$

輸入轉速  $\leq$  允許最高轉速  
減速比  $\leq$  允許最高轉速  
 $\frac{\text{input speed}}{\text{reduction ratio}} \leq \text{allowable maximum speed}$

$T_1$  or  $T_3 >$  啟動停止時允許轉矩  
 $T_1$  or  $T_3 >$  allowable torque for startup or stop

啟動時轉矩  $T_1$   
停止時轉矩  $T_3$   
torque for startup  $T_1$   
torque for stop  $T_3$

$T_1$  or  $T_3 \leq$  啟動停止時允許轉矩  
 $T_1$  or  $T_3 \leq$  allowable torque for startup or stop

$T_{em} >$  允許瞬時最大轉矩  
 $T_{em} >$  allowable torque for instantaneity

緊急停止時轉矩  $T_{em}$   
torque for emergency stop  $T_{em}$

$T_{em} \leq$  允許瞬時最大轉矩  
 $T_{em} \leq$  allowable torque for instantaneity

實際作用次數  $>$   $C_{em}$   
actual operation cycle  $>$   $C_{em}$

實際作用次數  $\leq$   $C_{em}$   
actual operation cycle  $\leq$   $C_{em}$

$$C_{em} = \frac{775 \times \left( \frac{5 \times T_o}{T_{em}} \right)^{\frac{10}{3}}}{40 \times \frac{N_{em}}{60} \times t_{em}}$$

容許作用次數計算  $C_{em}$   
allowable operation cycle calculation  $C_{em}$

目前所選  
**型號不適用**  
請再提高型號  
確保正確運作  
Inappropriate model,  
please enlarged the model to avoid over-load operation)

- $T_1$  = 啟動時轉矩
- $T_3$  = 停止時轉矩
- $N_o$  = 額定輸出轉速 (r/min)
- $N_m$  = 平均輸出轉速 (r/min)
- $T_o$  = 額定轉矩 (Nm)
- $T_m$  = 平均負載轉矩 (Nm)
- $M_t$  = 彎矩剛性 (Nm/arc.min)
- $W_1, W_2$  = 負荷 (N)
- $l_1, l_3$  = 到負荷點距離 (mm)
- $l_1 = l + \frac{b}{2} - a$
- $l$  = 輸出軸面到負荷點距離 (mm)
- $l_2 = l + b - a$
- $T_{m1}$  = 馬達瞬時最大轉矩
- $R$  = 實際速比
- $\eta$  = 啟動效率減速機



### 基本壽命 life

L <sub>h</sub>	壽命時間 : Hr	
L <sub>10</sub>	K	6,000

$$L_h = K * \frac{N_o}{N_m} * \left( \frac{T_o}{T_m} \right)^{\frac{10}{3}}$$

L<sub>h</sub> : 壽命時間

N<sub>m</sub> = 平均輸出轉速 ( r/min )

T<sub>m</sub> = 平均負載轉矩 ( Nm )

N<sub>o</sub> = 額定輸出轉速 ( r/min )

T<sub>o</sub> = 額定轉矩 ( Nm )

### 彎矩剛性 bending rigidity

$$\theta = ( W_1 l_1 + W_2 l_3 ) / ( M_t \times 10^3 )$$

θ = 輸出軸的傾斜角度 ( arc.mim )

M<sub>t</sub> = 彎矩剛性 ( Nm / arc.min )

W<sub>1</sub>, W<sub>2</sub> = 負荷 ( N )

l<sub>1</sub>, l<sub>3</sub> = 到負荷點距離 ( mm )

$$l_1 = l + \frac{b}{2} - a$$

l = 輸出軸面到負荷點距離 ( mm )

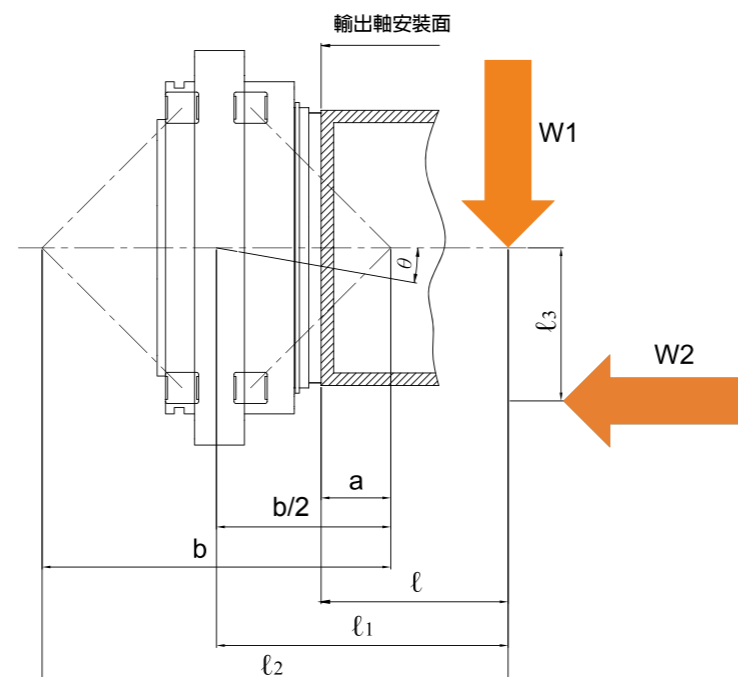

型號	彎矩剛性(Bending Rigidity) Nm/arc.min.	尺寸 (mm)	
		a	b
TTRA-5E	91	12.25	75.5
TTRA-7E	137	27.5	121
TTRA(RAC)-25E	447	30.75	146.5
TTRA(RAC)-45E	1036	36	168
TTRA(RAC)-135E	1238	58.5	231
TTRA(RAC)-165E	3022	64.75	250
TTRA(RAC)-325E	4957	76.5	293
TTRA-450E	7513	97	342
TTRAD-7E	137	27.5	121
TTRAD-25E	447	13.75	146.5
TTRAD-45E	1036	11.5	168
TTRAD-135E	1238	40.5	231
TTRAD-165E	3022	42.75	250
TTRAD-325E	4957	48.5	293
TTRAD-450E	7513	60	342
TTRV-6E	113	23.5	110
TTRV-20E	364	29.25	132.5
TTRV-40E	922	39.5	168
TTRV-80E	1168	47.75	196.5
TTRV-110E	1459	51	209
TTRV-160E	2933	66.75	250.5
TTRV-320E	4882	73	286.5
TTRV-450E	7434	93.5	347
TTRV(RD)-10C	419	30.75	137.5
TTRV(RD)-30C	1051	40	173
TTRV(RD)-50C	1942	55	213
TTRV(RD)-105C	2803	64	231
TTRV(RD)-200C	9789	92	335
TTRV(RD)-320C	12727	120	424
TTRV(RD)-500C	24488	148.5	510



● 為了充分發揮減速機的性能：

1. 建議使用德國 LUBRICANT 公司製造的潤滑脂 Li 801 EP。  
(註：請勿與其他的潤滑油混合使用)
2. 減速機的標準潤滑方式為潤滑脂潤滑。
3. 使用溫度範圍 (周圍溫度) -10°C~40°C。
4. 減速機內的潤滑脂用量：減速機在出廠時已注入本公司建議的 Lubrication 高負載多用途長效潤滑油脂 Li 801 EP。  
(註：顯示減速機內所需的注入量，不含與安裝側之間的空間。因此，有空間時，請將其填充。此外，過度填充可能會使內部氣壓升高、進而損壞油封，因此請確保占全部體積 10% 左右的空間。)
5. 在高速、高溫、低速、重荷重、強制潤滑等特殊情況下使用場合，請與本公司洽商。
6. 潤滑脂不足，可能導致減速機快速磨損和效率降低；而潤滑脂過多，則可能導致漏油。
7. 潤滑脂更換時間：潤滑脂在使用一定時間後會發生劣化的情況。減速機在注入適量潤滑脂的運轉情況下，潤滑脂的標準更換時間為 3,000 小時。
8. 潤滑脂受到污損或在惡劣的環境中 (周圍溫度在 40°C 以上) 使用減速機時，應隨時檢查潤滑脂的污損和劣化情況，適時進行更換。

● For making full use of the performance of reducer

1. Recommend to adopt Germany Lubricant brand of lubrication grease Li 801 EP anufactured by German Lubricant. (PS.: Please don't mixed with other lubricant.)
2. Grease lubricant is standard TSUNTIEN reducer lubrication.
3. Operating temperature range ( ambient temperature) -10°C~40°C
4. Lubricant volume : Filled high-load versatile & durative lubrication grease Li 801 E  
(PS.: Filled grease volume as the description of enclosed list , not include the inner space of mounting side. Please fill up the room of mounting side. Besides, over-filled grease may to raise inner pressure rapidly to result in the damage of oil seal during operation .Therefore , ensure grease occupied approximately 10% of the whole inner space .)
5. Ifused tom special conditions or environments , such as high speed, high temperature, low speed,heavy load, and forced lubrication, please contact our company.
6. Insufficient lubricant could resulted in noise , abrasion of components and low efficiency . Excessive lubricant may occur oil leakage.
7. Replaced period of lubricant : Suggest to replace lubricant every 3000 operating hours under regulative volume due to poor performance concern.
8. When reducer mostly operated in the contaminated or dirty environments ( ambient temperature over 40°C) , please inspect quality of lubricant regularly and replace with new lubricant timely.

安裝水平軸的情況

型式	需要注入量約 (cc)
RA-5E	80
RA-7E	101
RA-25E	164
RA-45E	369
RA-135E	640
RA-165E	1016
RA-325E	1812
RA-450E	1950

安裝垂直軸的情況

型式	需要注入量約 (cc)
RA-5E	80
RA-7E	106
RA-25E	172
RA-45E	387
RA-135E	672
RA-165E	1067
RA-325E	1902
RA-450E	2048

安裝水平軸的情況

型式	需要注入量約 (cc)
RAD-7E	101
RAD-25E	164
RAD-45E	369
RAD-135E	640
RAD-165E	1016
RAD-325E	1812
RAD-450E	1950

安裝垂直軸的情況

型式	需要注入量約 (cc)
RAD-7E	106
RAD-25E	172
RAD-45E	387
RAD-135E	672
RAD-165E	1067
RAD-325E	1902
RAD-450E	2048

安裝水平軸的情況

型式	需要注入量約 (cc)
RV-6E	80
RV-20E	96
RV-40E	215
RV-80E	421
RV-110E	475
RV-160E	693
RV-320E	1144
RV-450E	1756

安裝垂直軸的情況

型式	需要注入量約 (cc)
RV-6E	80
RV-20E	110
RV-40E	246
RV-80E	483
RV-110E	545
RV-160E	763
RV-320E	1312
RV-450E	2014

安裝水平軸的情況

型式	需要注入量約 (cc)
RV-10C	150
RV-30C	293
RV-50C	548
RV-105C	832
RV-200C	2014
RV-320C	3890
RV-500C	6527

安裝垂直軸的情況

型式	需要注入量約 (cc)
RV-10C	150
RV-30C	336
RV-50C	628
RV-105C	943
RV-200C	2284
RV-320C	4452
RV-500C	7590



## 安裝水平軸的情況

型式	需要注入量約 (cc)
RAC-25E	164
RAC-45E	369
RAC-135E	640
RAC-165E	1016
RAC-325E	1812

## 安裝垂直軸的情況

型式	需要注入量約 (cc)
RAC-25E	172
RAC-45E	387
RAC-135E	672
RAC-165E	1067
RAC-325E	1902

## 安裝水平軸的情況

型式	需要注入量約 (cc)
RD-10C	300
RD-30C	475
RD-50C	791
RD-105C	1077
RD-200C	2596
RD-320C	4265
RD-500C	7000

## 安裝垂直軸的情況

型式	需要注入量約 (cc)
RD-10C	300
RD-30C	523
RD-50C	870
RD-105C	1185
RD-200C	2856
RD-320C	4692
RD-500C	7700

- 1.當最終用途與軍事有關，且用於武器製造時，本產品可能成為「外匯管理法」中規定的限制出口產品，出口時，需進行充分的審查並辦理必要的出口手續。
- 2.本產品的故障或錯誤動作直接危及人的生命；本產品被用於可能影響人身安全的裝置(原子能設備、宇航設備、交通工具、醫療器械、各種安全裝置等)，有以上這些情況時，均必須進行認真的研究，請與本公司聯繫。
- 3.雖然本產品在製造時進行了嚴格的質量管理，但在有可能因故障影響人身安全及造成嚴重設備損失的機械上使用時，請設置安全裝置。
- 4.在特殊環境(清潔室、食品等)下使用本產品時，請事先與本公司聯繫。
- 5.在使用中，禁止使用反工程等方法對本產品進行分解和內部解析。

1. End-user application related to military affairs and weapon production can make the products to become export restriction goods under the regulation on the Foreign Exchange Management. When exporting, sufficient examination paper and necessary export procedures need to be conducted.
2. Malfunction and misuse can jeopardize human life directly—applying the products to facilities related to nuclear power, space navigation, transportation, medication care, life safety equipment have to be arefully evaluated and contact us.
3. The products are manufactured under high-level quality control ; however, any unpredictable breakdown can endanger human safety and cause serious damage of machine , an security mechanism is necessary to be set up.
4. Operating the products in specific environments (sanitary,food,etc.),please inform us in advance.
5. "Reverse engineering" is strictly forbidden to take apart the products and analyze inside components.

## 保固 Warranty

- 1.TSUNTIEN公司保證減速機在材料、製造方面沒有缺陷。
- 2.在本公司規定的額定運轉條件內，在正常的裝配狀態以及潤滑狀態下使用，本產品的保固期為交貨後一年，或者實機搭載後運轉2,000小時，以兩者中較早到期的時間為準。
- 3.一旦在上述保固期內發現材料、製造方面的缺陷，而該產品的修理或更換的相關費用由本公司承擔。但是，實機拆卸以及安裝所需的工時、再次交貨所需的運費、稅金、倉儲費用等附帶費用不在本公司承擔範圍。
- 4.因本產品不適合而引起搭載實機停機時導致的損失費用，本公司概不負責。
- 5.需要以金額進行賠償時，賠償金額的上限將不超過索賠對象產品的銷售價格。
- 6.在沒有事先通知本公司的情況下，擅自分解該產品、或重新組裝該產品，由此引發性能方面、安全方面的問題等，本公司一概不予負責。

1. TSUNTIEN mensues roller reducers no defectsm in material and manufacture.
2. TSUNTIEN provide either warranty period one year after delivery or 2000 operation hours , depend on which one is reached earlier , be valid under regulated operation conditions , normal installation and lubrication.
3. Any defects of material and manufacture during warranty period , the fees of repair and replacement will be in charge of TSUNTIEN.But we are not responsible for work hours of disassembly and installation and for cost of shipping , tax and warehouse.
4. TSUNTIEN is not responsible for the cost of shutdown due to improper model selection.
5. The maximum amount of compensation is under selling price of damage product .
6. Once problems occurred in performance , safety or others , TSUNTIEN is not responsible regarding customers disassemble or assemble by themselves without previous notification .

# 村田精密有限公司

ADD:43750 台中市大甲區中山路一段312號

TEL:+886-4-26888973 ( 代表號 )

FAX:+886-4-26888547

e-mail:support@tsuntien.com.tw

www.tsuntien.com.tw